

*Distance between the higher part of the head pulley and the shaft roof

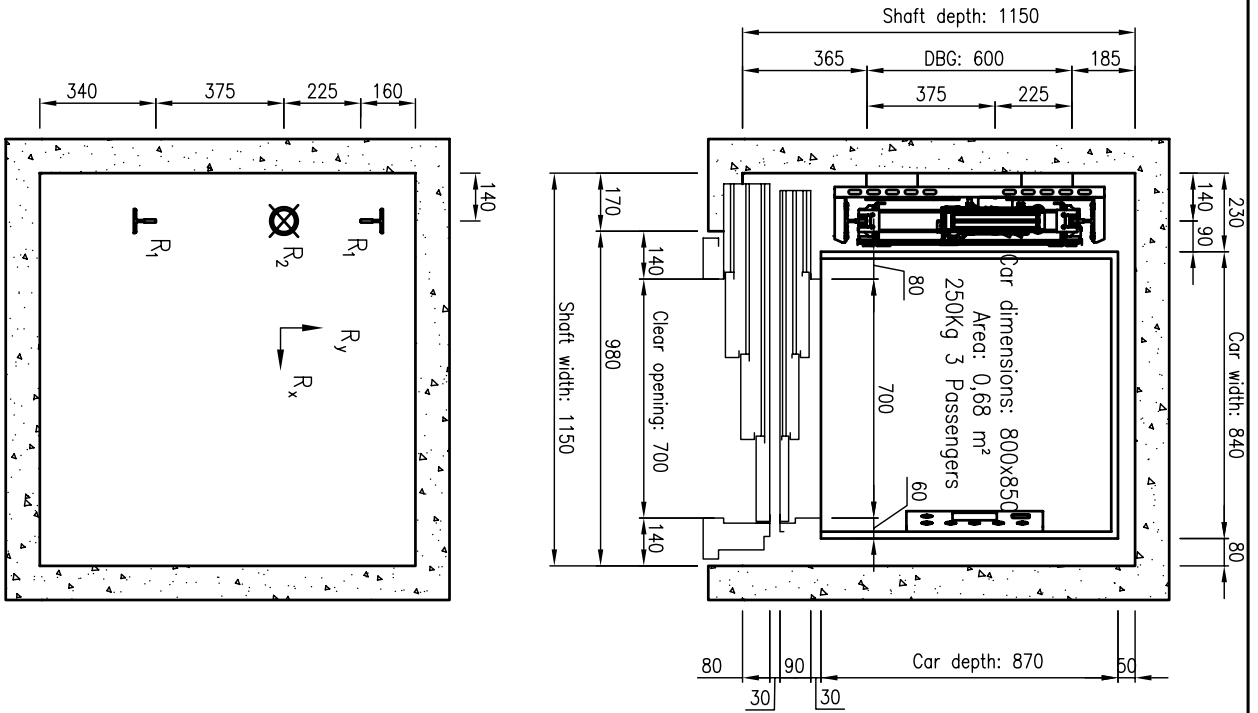
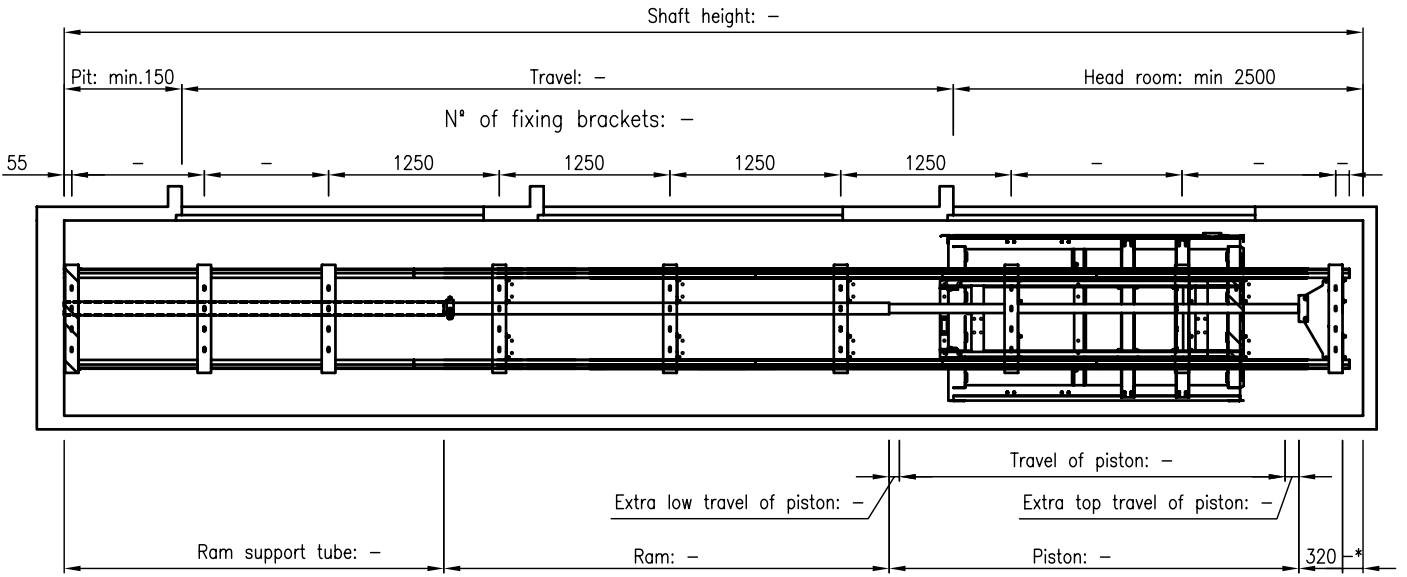

| CHARACTERISTICS | |
|----------------------|--------------|
| LOAD: | 250 Kg |
| PASSENGERS: | 3 |
| RATED SPEED: | 0,15 m/s |
| TRAVEL: | - mm |
| STOPS: | - |
| ACTION: | 2:1 |
| HEAD PULLEY: | ø250 |
| TRACTION ROPES: | 2x9ø |
| CAR GUIDES: | G7 (70/65/9) |
| CAR SAFETY GEAR: | PI-12 |
| PISTON: | 65/75 |
| HYDRAULIC EQUIPMENT: | GMW HL6000 |
| MOTOR POWER: | 2 Cv |
| PUMP FLOW: | 15 l/min |
| START: | DIRECT |
| NOMINAL CURRENT: | 16 A |
| START CURRENT: | 52 A |
| R1: | 12.000 N |
| R2: | 19.000 N |
| Rx: | 4.000 N |
| Ry: | 1.100 N |

| N° OF PIECES | | DENOMINATION | | POS. MATERIAL | | WEIGHT | | DRAWING | |
|---------------|---|--------------|---|---------------|------|-------------------|--|--------------------------------|--|
| 4 | 3 | 2 | 1 | Date | Name | CUSTOMER | | | |
| GROUPS | | Drawn | | | | | | Falesa | |
| V.B. | | | | | | | | FABRICACION DE ELEVADORES S.L. | |
| Scale: | | S:E | | SHAFT LAYOUT | | 250Kg 3Passengers | | | |
| Subs. Draw N° | | | | Replaced by: | | | | Ed:0 | |
| Date | | | | Modification | | | | | |