

Minimum pit: 1100
 Travel:
 Total height:
 Minimum headroom: 3600

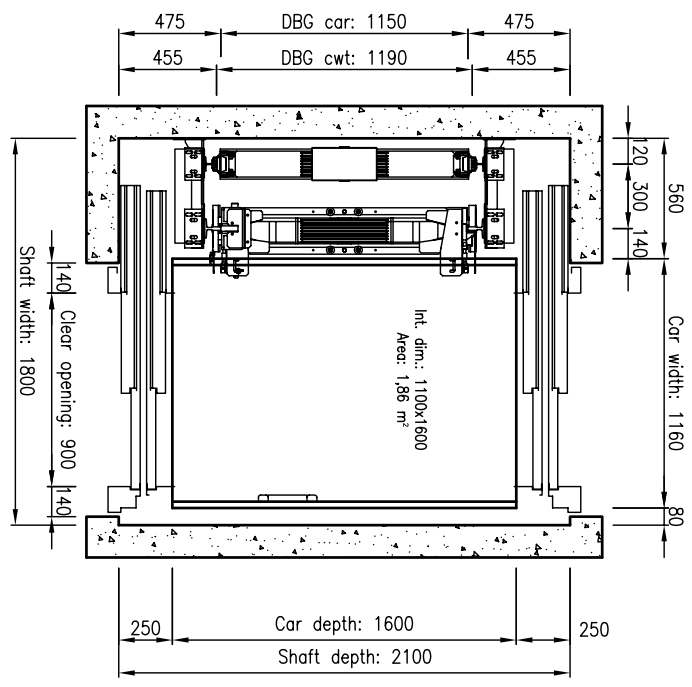

SHAFT PLAN

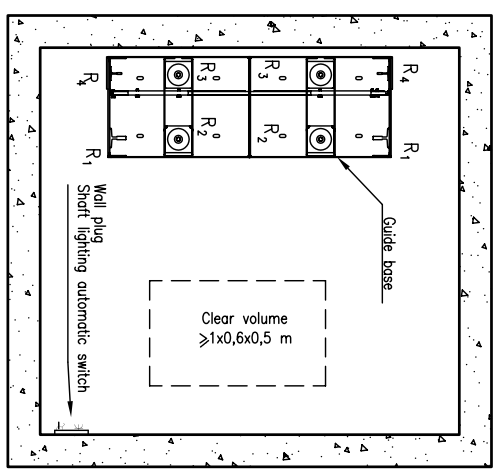

PIT

CHARACTERISTICS	
LOAD:	800 Kg
PERSONS:	10
RATED SPEED	1 m/s VF
TRAVEL:	- mm
FLOORS:	-
SEQUENCE:	-
MACHINE DENOMINATION:	DIAM-10-800-2S
TRACTION PULLEY:	ø330
DEFLECTION PULLEY:	ø400
SUSPENSION:	2:1
TRACTION ROPES:	6x8ø
OVERSPEED GOV. ROPE:	ø6
CWT GUIDE RAIL:	65/54/8
CAR GUIDE RAIL:	90/75/16
CWT SAFETY GEAR: (if required)	-
CAR SAFETY GEAR	F2S
CAR BUFFER(2):	ø100/80
CWT BUFFER(2):	ø100/80
MACHINE POWER:	7,5 CV
POWER VOLTAGE:	380 V
LIGHTING VOLTAGE:	220 V
PHASES:	3
NOMINAL CURRENT:	11,7 A
START CURRENT	11,7 A
R1:	24,118 N
R2:	33,354 N
R3:	25,506 N
R4:	16,265 N

N° OF PIECES		DENOMINATION		POS MATERIAL WEIGHT		DRAWING	
4	3	2	1	2008	Date:	20-10	VGM
GROUP		CUSTOMER		Scale:		GRL 800	
S-E		S-E		Subs Draw N°:		I-2/-	
Ed.0		Replaced by:		Ed.0		Ed.0	

