

www.felesa.com



μGRL
microGRL



...especial rehabilitaciones
...especial huecos reducidos

..foso reducido
..huida reducida
..huecos mínimos
..cabinas máximas

FELESA



Especialmente destinado a:

Reformas

Reducción volúmenes no útiles

Aplicable al número máximo de instalaciones

Ahorro energético

Reducción consumos con máquinas gearless

Utilización aceros altas resistencias

Confort

Aislamiento instalacion

Reducción ruidos y vibraciones

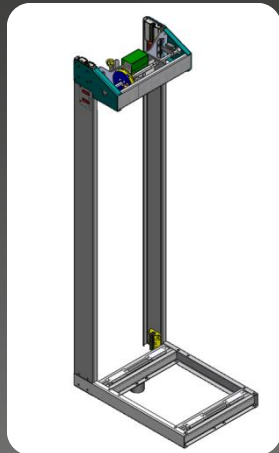

Características Especiales

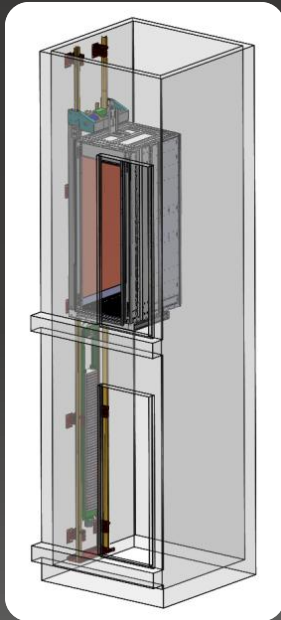

Foso: 300mm

Huida: 2700mm

Distancia Pared-Cabina: 250mm

(anchura mecánica 730mm)

Monofásico 220v

Trifásico 380v

Normativa

EN81-1:1998

EN81-1:2001/A2

EN81-21:2009

examen CE Diseño

EN81-1:1998 apdos. 9.1.2a 9.2.1



Rango

Carga: 180kg-630kg

Velocidad: 1m/s

Tracción: 2:1

Máquina gearless

Con/Sin cuarto de máquinas

Facilidad de montaje

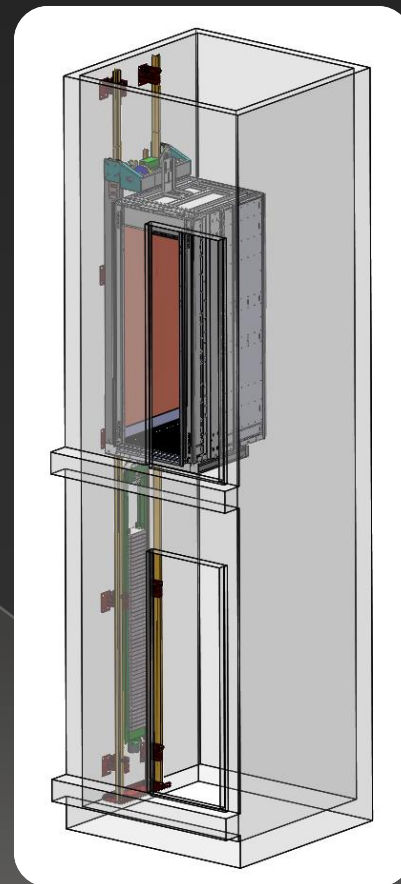

Tipos

μGRL-1

Foso: 300mm

Huida: 3400mm

Pared-Cabina: 250mm

Mecánica: 730mm

μGRL-2

Foso: 300mm

Huida: 2700mm

Pared-Cabina: 340mm

Mecánica: 730mm

Detalle planta

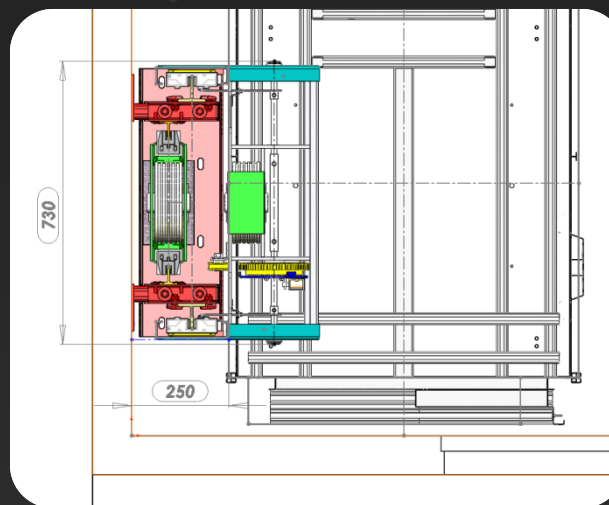

Detalle foso

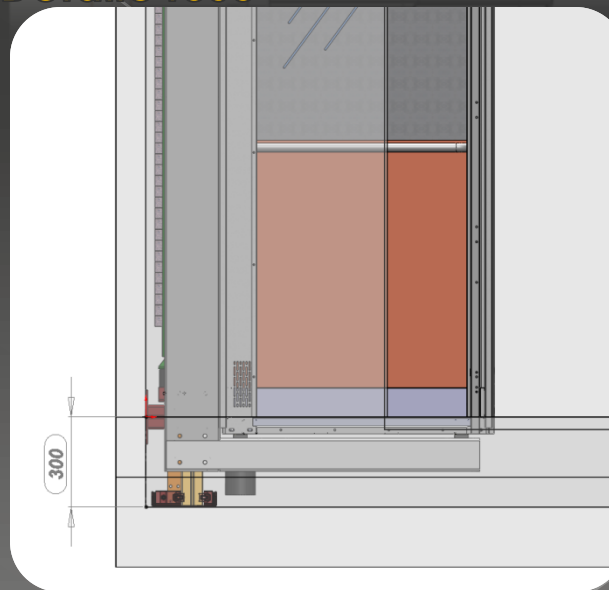

Guías

Guías enfrentadas
Guías cabina RF70
Guías contrapeso RT45
Regulación continua
Fijaciones aisladas

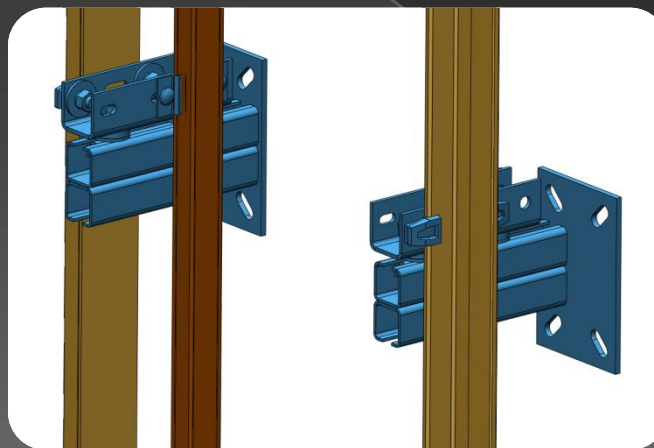
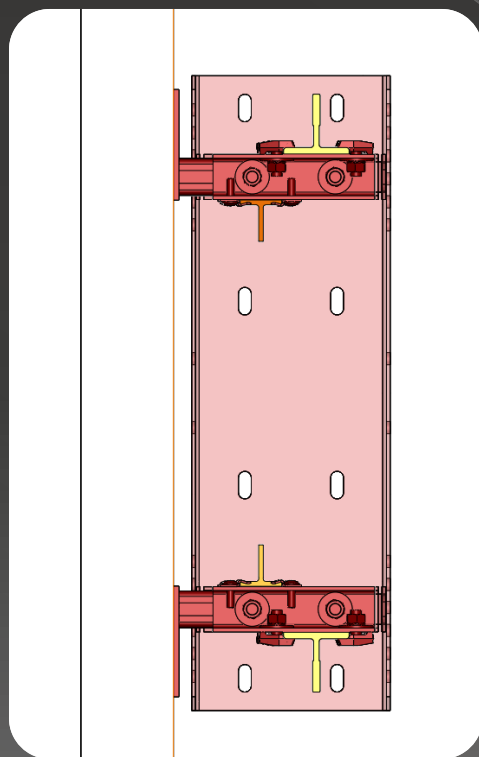

Estribo

Estribo Mochila

Polea $\varnothing 200$

Cables $\varnothing 6,5$

Paracaídas+accionamiento+limitador
velocidad parte superior chasis

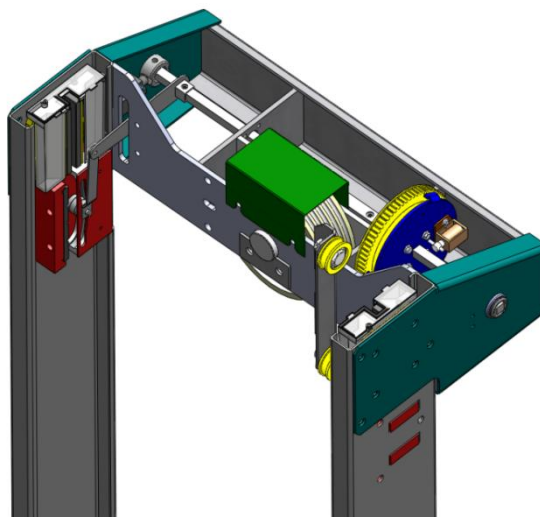
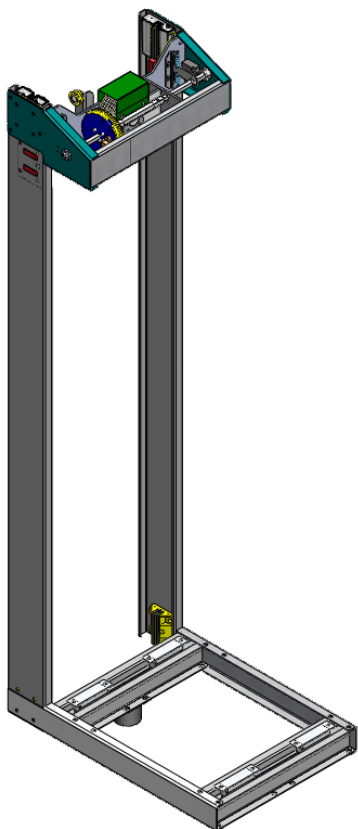

Contrapeso

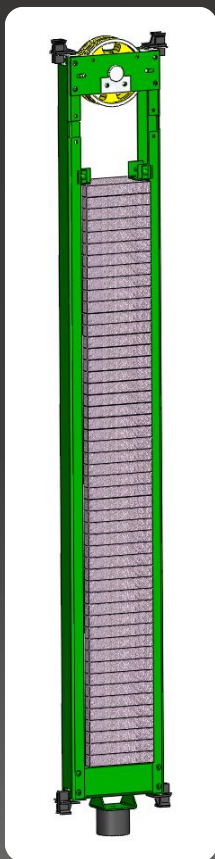

Contrapeso diferencial 2:1

Polea $\varnothing 200$ 6,5 \varnothing

Tiro centrado

Pesas acero



Máquina+Bancada

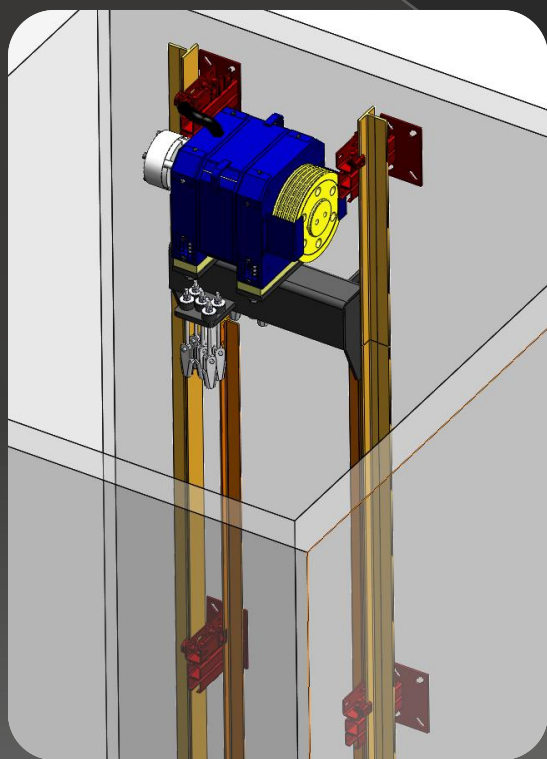

Peso y dimensiones reducidas
(220x400x270mm)

Polea motriz $\varnothing 200$ 5x6,5 \varnothing

Trifásica o monofásica.

Bancada apoyada sobre las dos guías de cabina y contrapeso.

Atado cables cabina y contrapeso sobre bancada.

Máquina aislada.

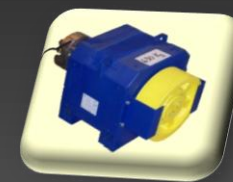

Periféricos

Limitador de velocidad con correa dentada.

Pesacargas células electrónico.

Variador Fuji Frenic.

Armario marco puerta reducido en puerta piso (cualquier planta)

Opcional:

Dispositivos cumplimiento EN81-21

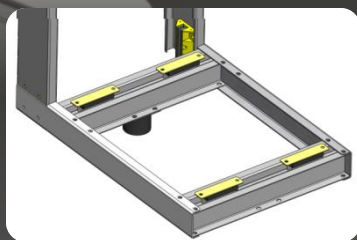
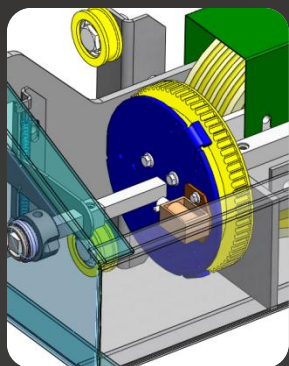

Replanteos

Mecánica trasera

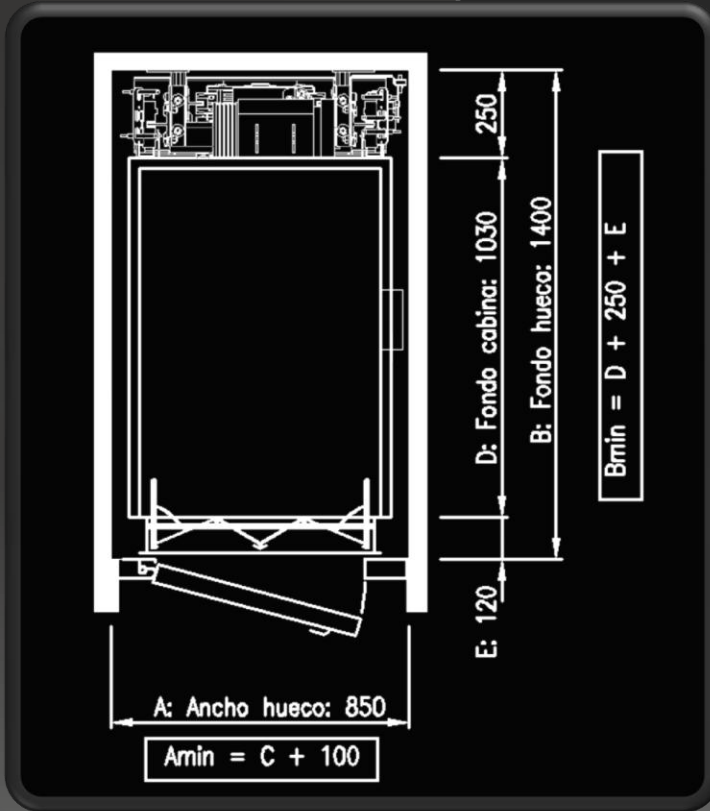

Mecánica lateral

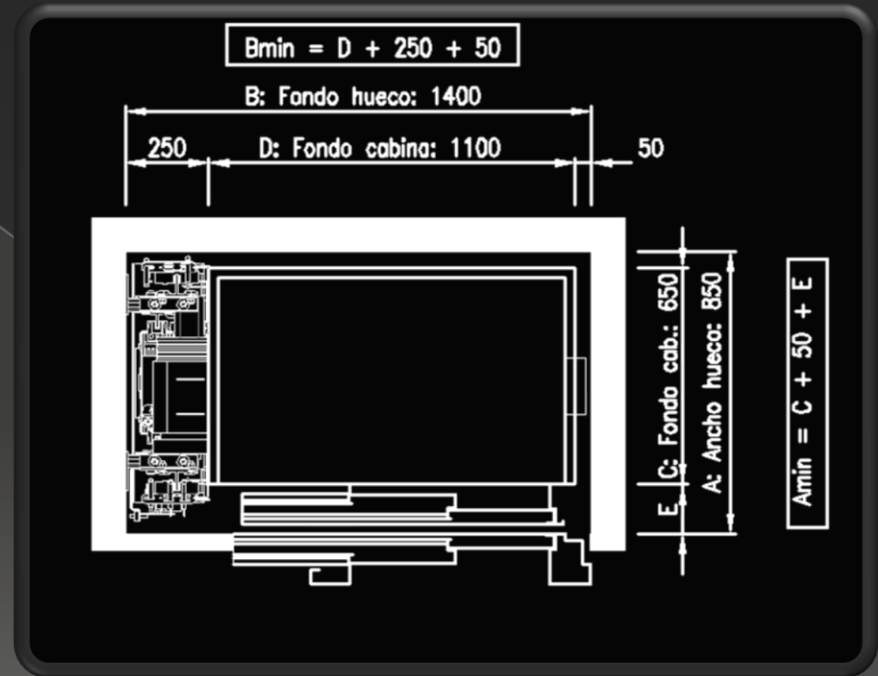

Ancho hueco mínimo: 850mm



Cabinas

Combinación con gama
ACUARELA



Moving forward & moving on

www.felesa.com

