

*Distance between the higher part of the head pulley and the shaft roof

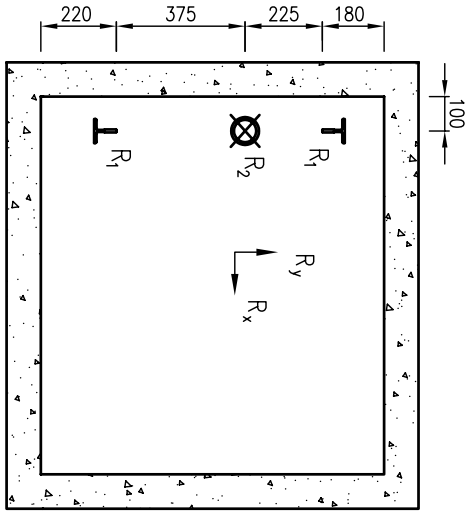
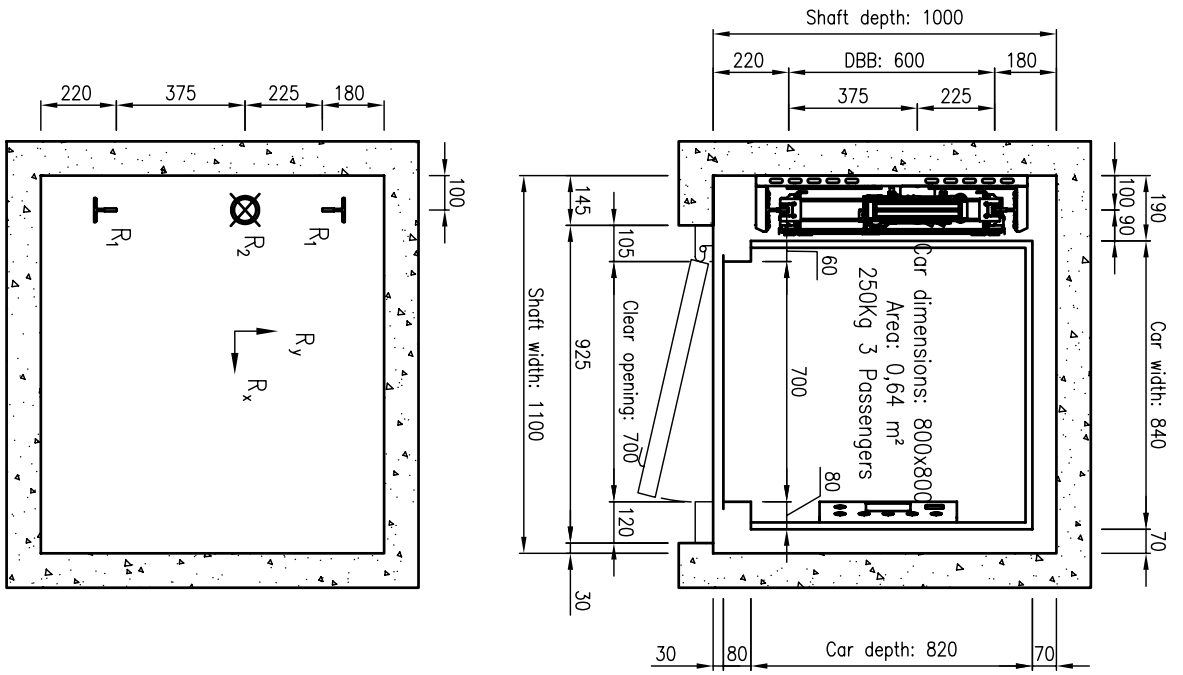
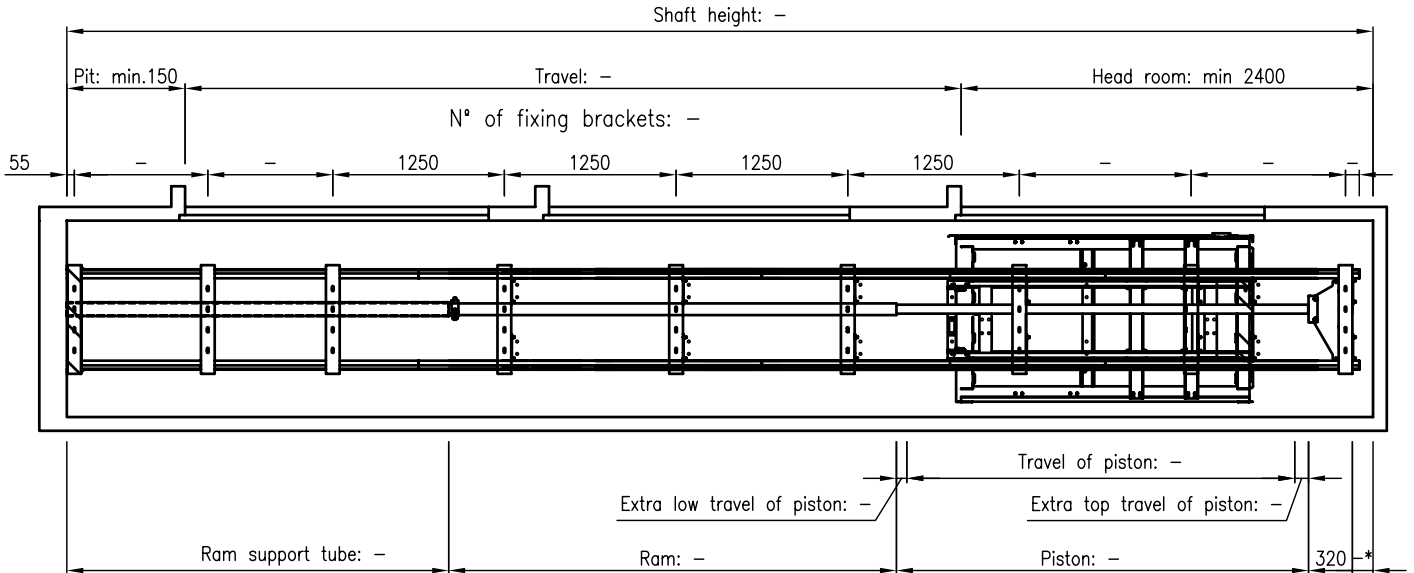

CHARACTERISTICS	
LOAD:	250 kg
PASSENGERS:	3
RATED SPEED:	0,15 m/s
TRAVEL:	- mm
STOPS:	-
ACTING:	2:1
HEAD PULLEY:	Ø250
TRACTION ROPES:	2x9ø
CAR GUIDES:	G7 (70/65/9)
CAR SAFETY GEAR:	Pl-12
PISTON:	65/7,5
HYDRAULIC EQUIPMENT:	GMV HL6000
MOTOR POWER:	2 Cv
PUMP FLOW:	15 l/min
START:	DIRECT
NOMINAL CURRENT:	16 A
START CURRENT:	52 A
R1:	12.000 N
R2:	19.000 N
Rx:	4.000 N
Ry:	1.100 N

Nº OF PIECES		DENOMINATION		POS. MATERIAL WEIGHT		DRAWING	
4	3	2	1	Date	Name	CUSTOMER	RELASA FABRICACION DE ELEVADORES S.L.
GROUPS		Drawn					
		V1 B1					
		Scale:					
		S-E					
		SHAFT LAYOUT					
		250Kg 3Passengers					
		Subs Draw N°					
		Replaced by:					
		Date					Ed:0
		Modification					