

*Distance between the higher part of the head pulley and the shaft roof

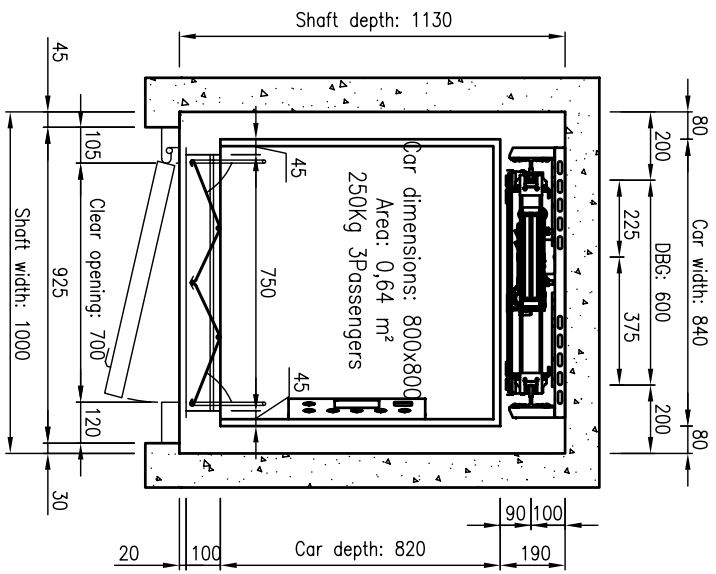
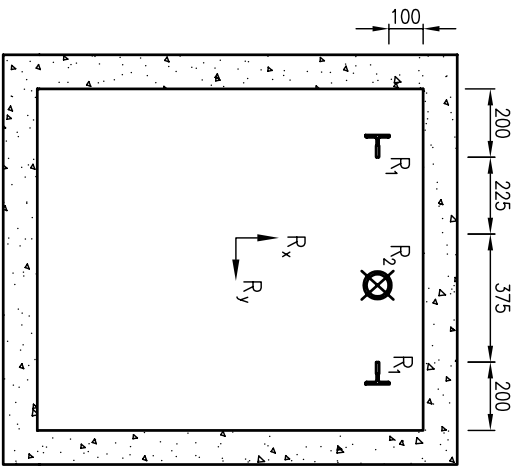
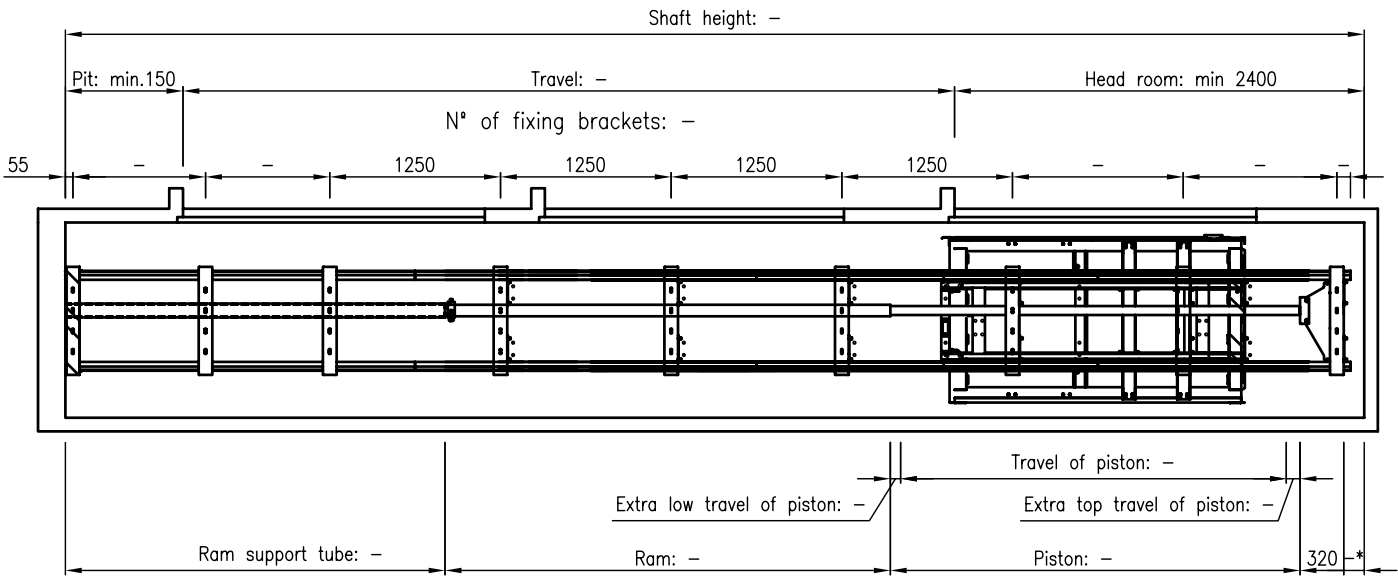

CHARACTERISTICS	
LOAD:	250 Kg
PASSENGERS:	3
RATED SPEED:	0,15 m/s
TRAVEL:	- mm
STOPS:	-
ACTING:	2:1
HEAD PULLEY:	ø250
TRACTION ROPES:	2xø
CAR GUIDES:	67 (70/65/9)
CAR SAFETY GEAR:	PI-12
PISTON:	65/7,5
HYDRAULIC EQUIPMENT:	GMW HL6000
MOTOR POWER:	2 Cv
PUMP FLOW:	15 l/min
START:	DIRECT
NOMINAL CURRENT:	16 A
START CURRENT:	52 A
R1:	12.000 N
R2:	19.000 N
Rx:	4.000 N
Ry:	1.100 N

N° OF PIECES		DENOMINATION		POS. MATERIAL		WEIGHT		DRAWING	
4	3	2	1	Date	Name	CUSTOMER		Falesa	
GROUPS		Drawn						FABRICATION DE ELEVADORES S.L.	
V.B.									
Scale:		S.E		SHAFT LAYOUT		250Kg 3Passengers			
Date		Modification		Subs. Draw N°		Replaced by:		Ed.:0	