

*Distance between the higher part of the head pulley and the shaft roof

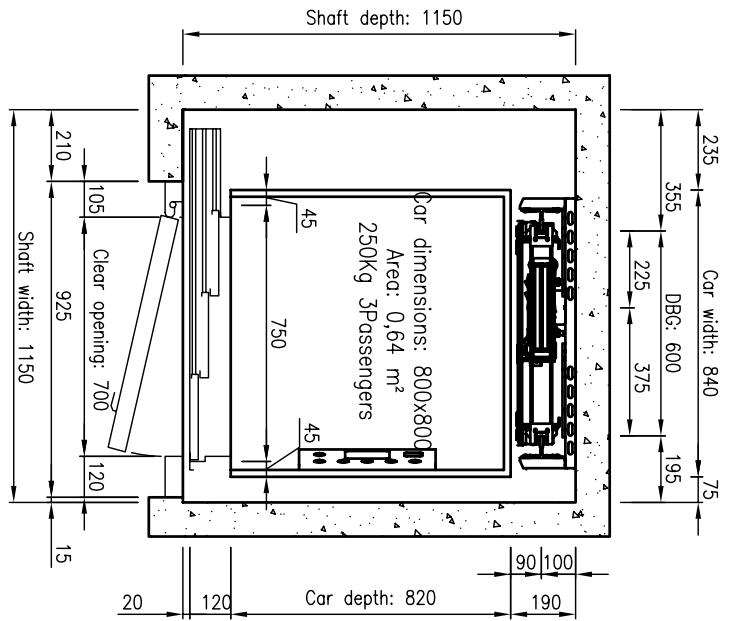
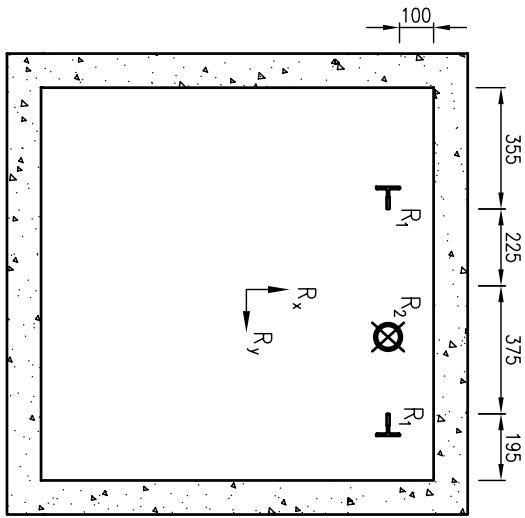
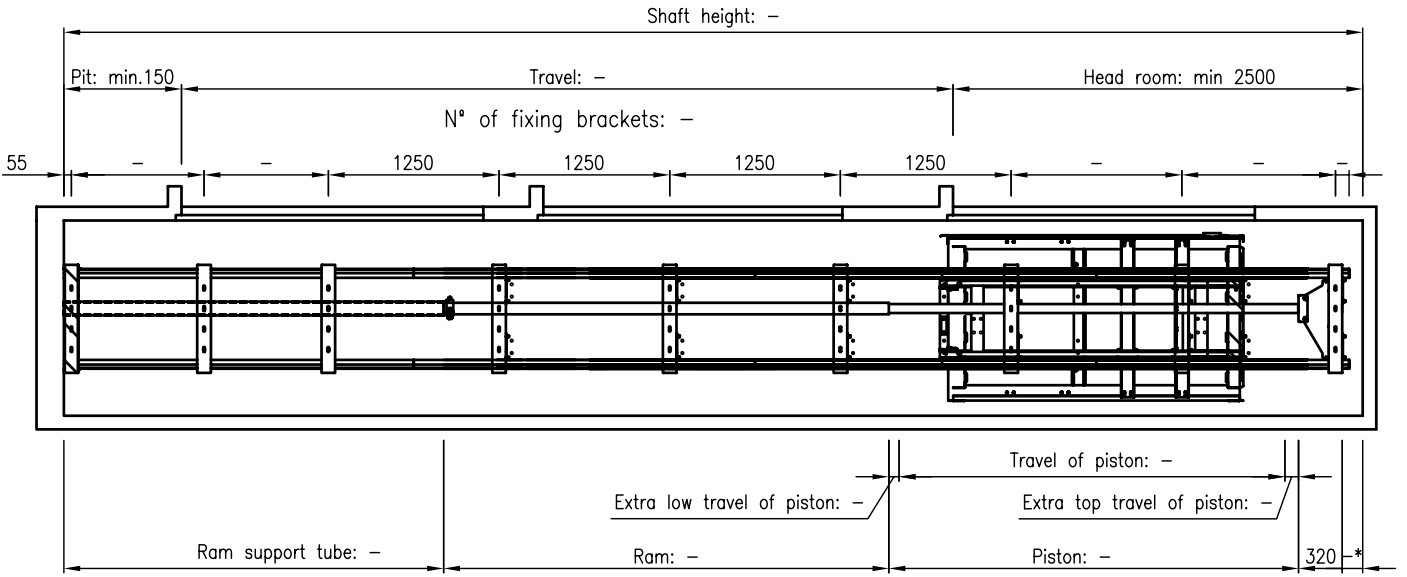

CHARACTERISTICS	
LOAD:	250 Kg
PASSENGERS:	3
RATED SPEED:	0,15 m/s
TRAVEL:	- mm
STOPS:	-
ACTING:	2:1
HEAD PULLEY:	ø250
TRACTION ROPES:	2x3ø
CAR GUIDES:	67 (70/65/9)
CAR SAFETY GEAR:	PI-12
PISTON:	65/75
HYDRAULIC EQUIPMENT:	GMW HL6000
MOTOR POWER:	2 Cv
PUMP FLOW:	15 l/min
START:	DIRECT
NOMINAL CURRENT:	16 A
START CURRENT:	52 A
R1:	12.000 N
R2:	19.000 N
Rx:	4.000 N
Ry:	1.100 N

Date	Modification

N° OF PIECES	DENOMINATION	POS. MATERIAL	WEIGHT	DRAWING
4	Date	Name	CUSTOMER	Falesa FABRICACION DE ELEVADORES S.L.
3	Drawn			
2	V.B.			
1				
Scale: S:E SHAFT LAYOUT				
Subst. Draw N° Replaced by: Ed:0				
250Kg 3Passengers				