

Moving forward & Moving on

FELES 



MTD
CarLift

- Applications
- Advantages
- Normative
- Application range
- Configurations
- Power and consumptions
- Cabines and finishes
- Gallety

Fiability + Experience



Designed for the vertical transport of vehicles on short travels. They are indicated for buildings where it is unfeasible or very complicated to place an access ramp.



Applications

- New Building/ Existing
- Lift for vehicles
- Residential / Industrial

Advantages

- Alternative to ramp parking
- Confort
- Fiability
- Safety
- Simple, double entrances
- Direct Acting 1:1 Easy assembly

Standards

- 2014/33/UE
- EN81-20
- EN81-70
- EN81-73

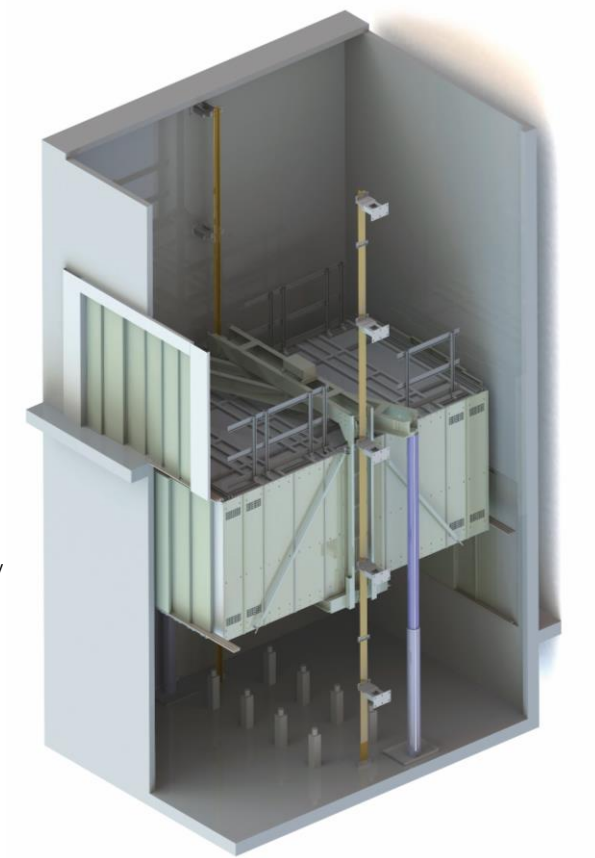

Application range

Load (Kg)	3000-3500-4000
Speed (m/s)	0,2 - 0,6
Motor room	With motor room
Entrances	0° / 180°
Travel Max (m)	20
Suspension	1:1
Voltage (V)	400III
Car frame	Standard car frame
Pit (mm)	1200
Headroom(mm)	3400
Panoramic	No



Standard configurations

➤ Single Entry

Load	Shaft	Cabine	Clear Op	Speed	HR	Pit	Handrail
Kg	AxB mm	CxD mm	E mm	m/s	mm	mm	mm
4000	3280x6100	2400x5700	2300	0,3-0,6	3400	1200	700
	3280x6100	2400x5600	2300	0,3-0,6	3400	1200	700
	3380x6000	2500x5600	2300	0,3-0,6	3400	1200	700
	3380x5800	2500x5400	2300	0,3-0,6	3400	1200	700
	3380x5600	2500x5200	2300	0,3-0,6	3400	1200	700
	3480x5800	2600x5400	2300	0,3-0,6	3500	1300	700
	3480x5600	2600x5200	2300	0,3-0,6	3500	1300	700
	3480x5400	2600x5000	2300	0,3-0,6	3500	1300	700

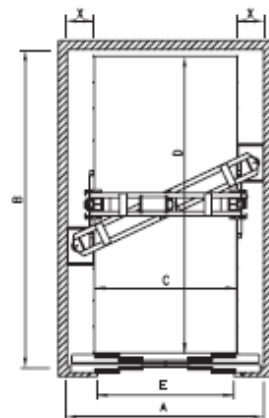

➤ Double Entry 180°

Load	Shaft	Cabine	Clear Op	Speed	HR	Pit	Handrail
Kg	AxB mm	CxD mm	E mm	m/s	mm	mm	mm
4000	3280x6200	2400x5700	2300	0,3-0,6	3400	1200	700
	3280x6100	2400x5600	2300	0,3-0,6	3400	1200	700
	3380x6100	2400x5600	2300	0,3-0,6	3400	1200	700
	3380x5900	2500x5400	2300	0,3-0,6	3400	1200	700
	3380x5700	2500x5200	2300	0,3-0,6	3400	1200	700
	3480x5900	2600x5400	2300	0,3-0,6	3500	1300	700
	3480x5700	2600x5200	2300	0,3-0,6	3500	1300	700
	3480x5500	2600x5000	2300	0,3-0,6	3500	1300	700

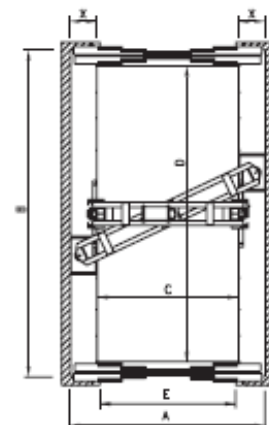

Configurations

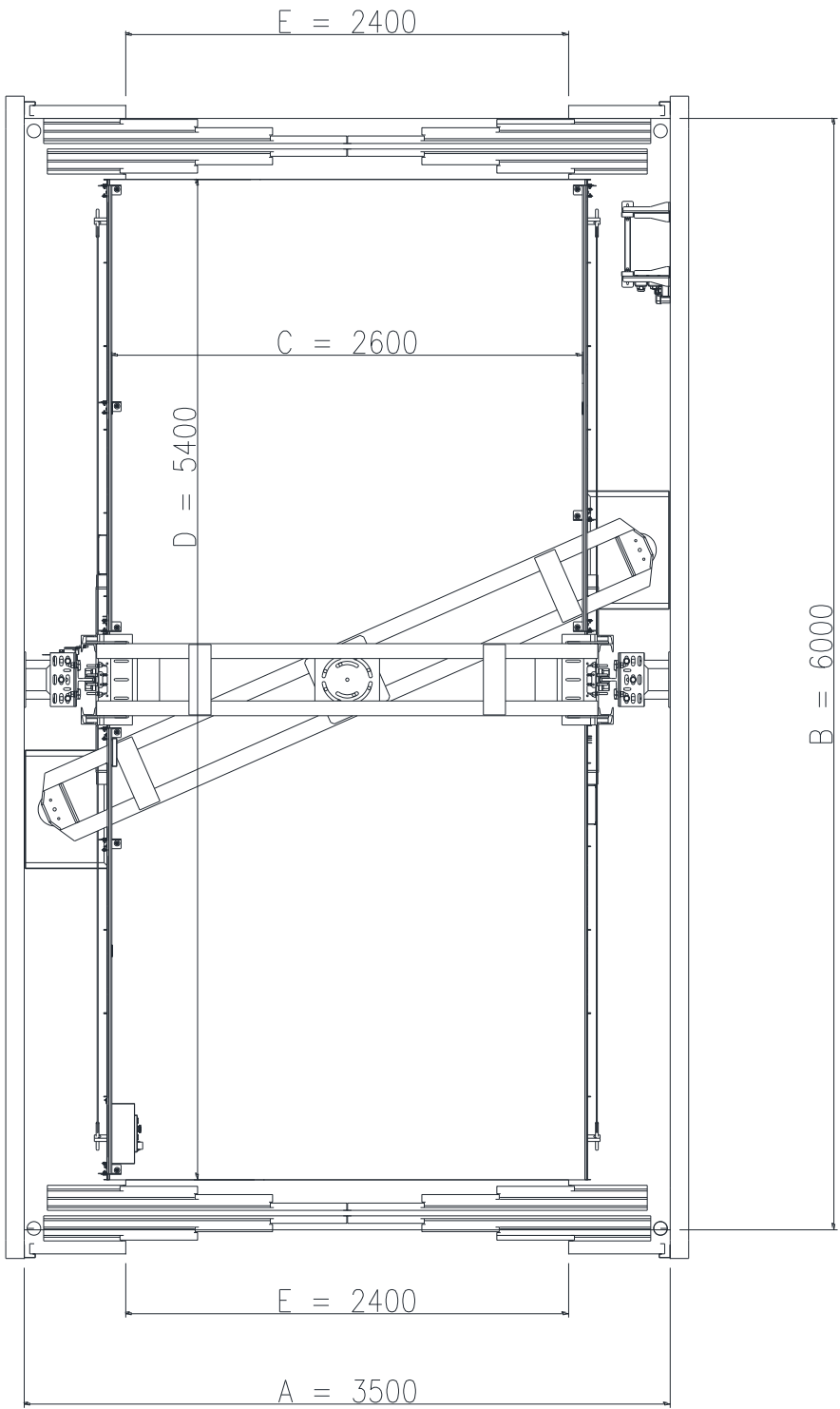

Configurations

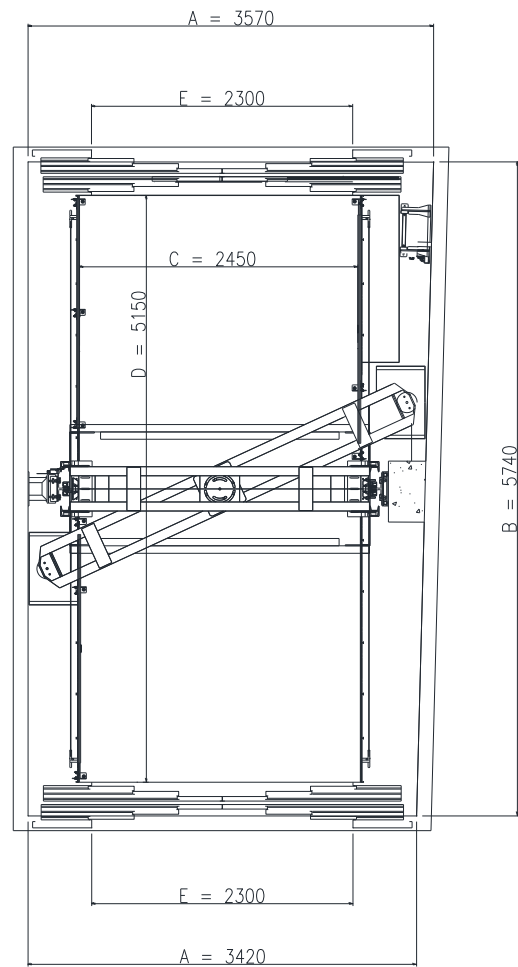
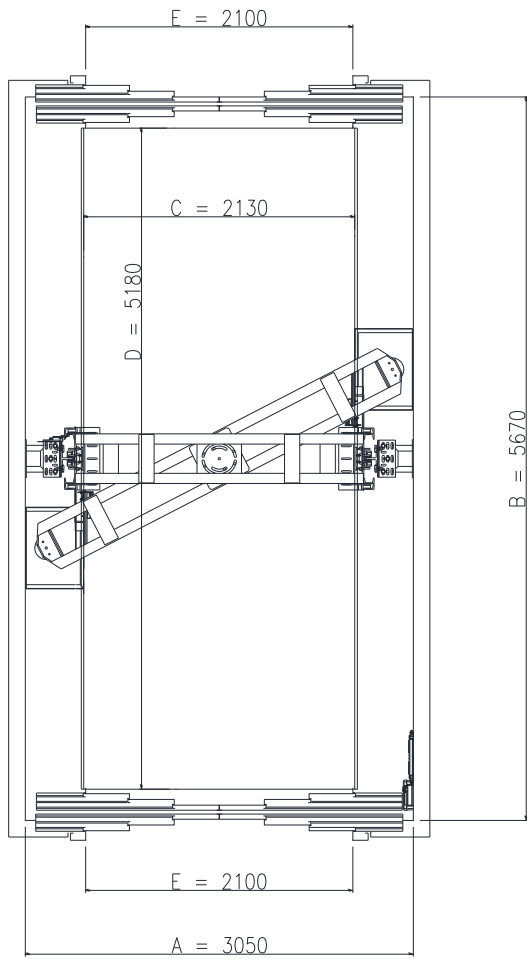

Configurations

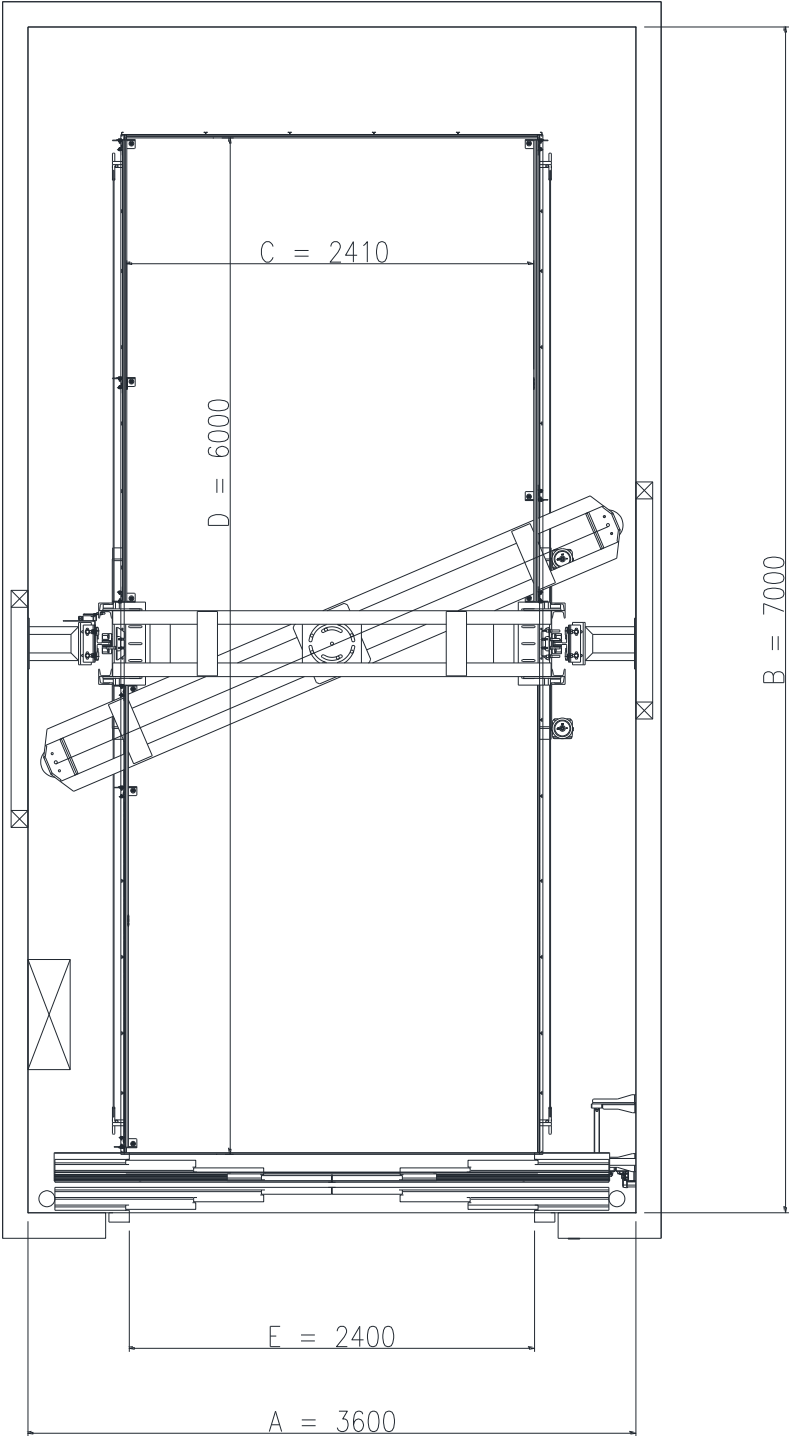

Power and Consumptions



➤ 2 cylinder / 1:1

3-phase	3000 Kg		3500Kg		4000Kg	
Tensión	380III		380III		380III	
P (Kw)	22Kw/30HP	44Kw/60HP	18,4Kw/25HP	29,4Kw/40HP	51Kw/70HP	59Kw/80HP
V (m/s)	0,30	0,63	0,30	0,63	0,30	0,63
I nominal (A)	51	101	68	118	84	134
I start(A)	74	152	98	181	130	208
Start	Star/Delta		Star/Delta		Star/Delta	

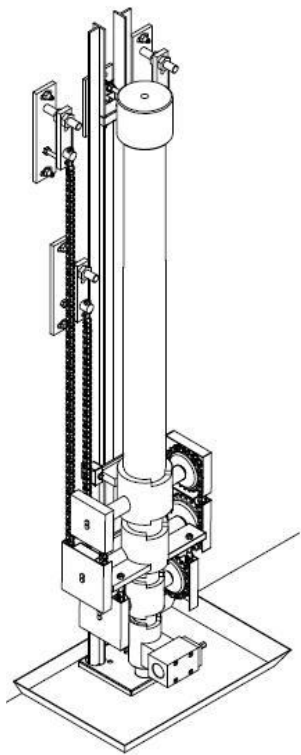

Cabines and finishes

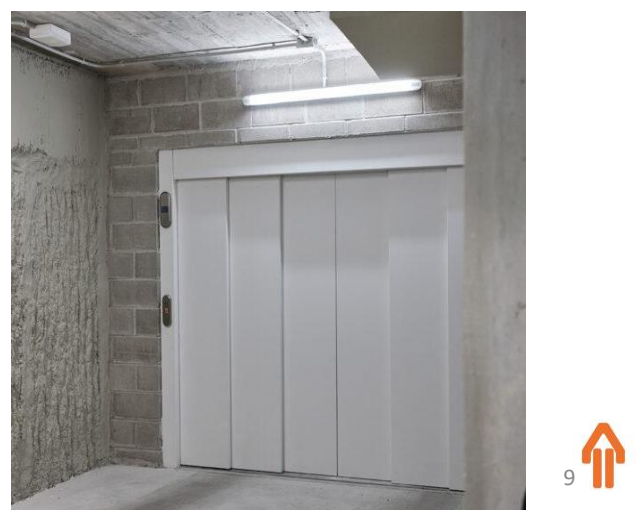
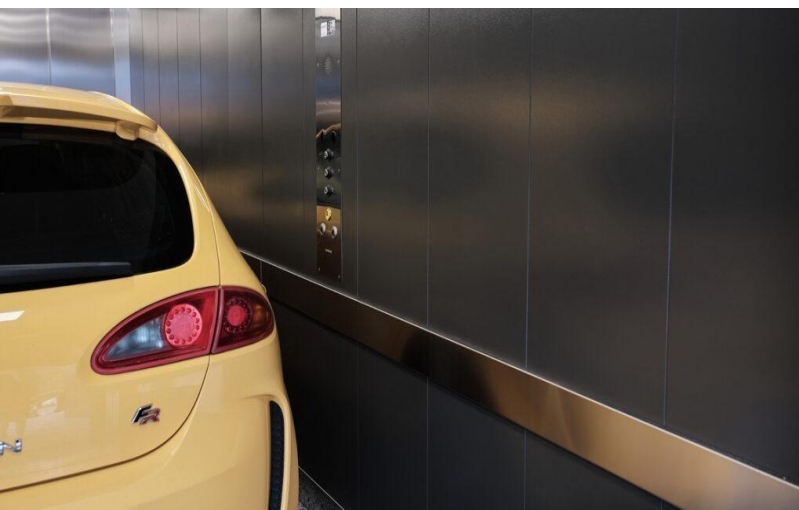
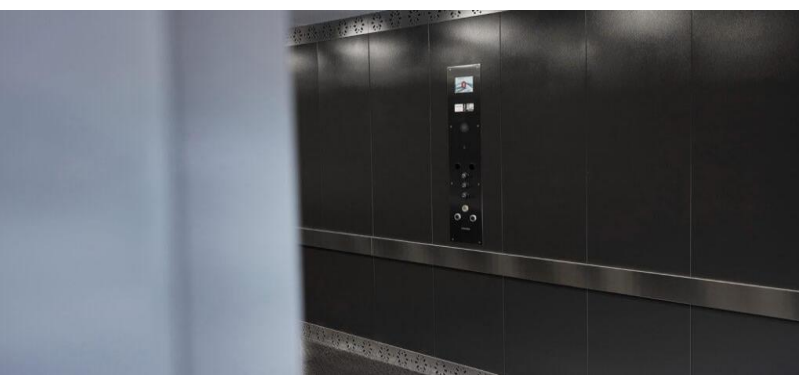

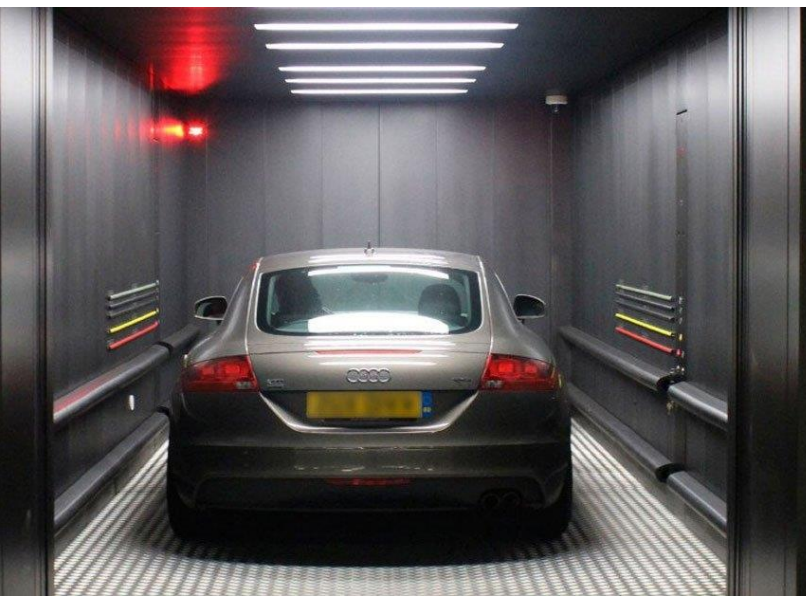
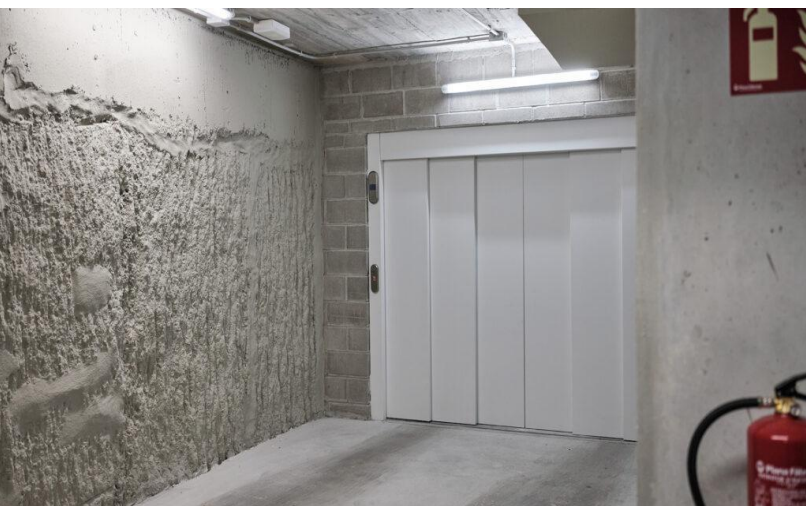

FELES 



www.felesa.com

Moving forward & Moving on