

Moving forward & Moving on

FELES 



MTD
MonteVoitures

- Applications
- Avantage
- Normative
- Champ d'application
- Configurations
- Consommations
- Cabines et finitions
- Galerie

Fiabilité+ Expérience



Conçus pour le transport vertical des voitures sur distances courtes. Parfaits pour bâtiments où il est très difficile avoir une rampe d'accès ou très compliqué



Application

- Nouvelle construction / Existant
- Ascenseur pour voitures
- Résidentiel / Industriel

Avantages

- Alternative à rampe parking
- Confort
- Fiabilité
- Sécurité
- Simples, doubles
- Traction 1:1 – Facile montage

Normatives

- 2014/33/UE
- EN81-20
- EN81-70
- EN81-73



Champ application

Charge (Kg)	3000-3500-4000
Vitesse (m/s)	0,2 - 0,6
Salle machinerie	Avec salle machinerie
Accès	0° / 180°
Course Max (m)	20
Traction	1:1
Tension (V)	400III
Étrier	Portique
Fosses (mm)	1200
Extra-course (mm)	3400
Panoramique	Non



Configurations standard

➤ Simple accès

Charge	Gaine	Cabine	Pass Libre	V	HDN	Fosse	Barriè.
Kg	AxB mm	CxD mm	E mm	m/s	mm	mm	mm
4000	3280x6100	2400x5700	2300	0,3-0,6	3400	1200	700
	3280x6100	2400x5600	2300	0,3-0,6	3400	1200	700
	3380x6000	2500x5600	2300	0,3-0,6	3400	1200	700
	3380x5800	2500x5400	2300	0,3-0,6	3400	1200	700
	3380x5600	2500x5200	2300	0,3-0,6	3400	1200	700
	3480x5800	2600x5400	2300	0,3-0,6	3500	1300	700
	3480x5600	2600x5200	2300	0,3-0,6	3500	1300	700
	3480x5400	2600x5000	2300	0,3-0,6	3500	1300	700

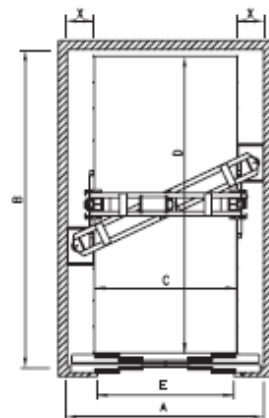

➤ Double accès 180°

Charge	Gaine	Cabine	Pass Libre	V	HDN	Fosse	Barriè.
Kg	AxB mm	CxD mm	E mm	m/s	mm	mm	mm
4000	3280x6200	2400x5700	2300	0,3-0,6	3400	1200	700
	3280x6100	2400x5600	2300	0,3-0,6	3400	1200	700
	3380x6100	2400x5600	2300	0,3-0,6	3400	1200	700
	3380x5900	2500x5400	2300	0,3-0,6	3400	1200	700
	3380x5700	2500x5200	2300	0,3-0,6	3400	1200	700
	3480x5900	2600x5400	2300	0,3-0,6	3500	1300	700
	3480x5700	2600x5200	2300	0,3-0,6	3500	1300	700
	3480x5500	2600x5000	2300	0,3-0,6	3500	1300	700

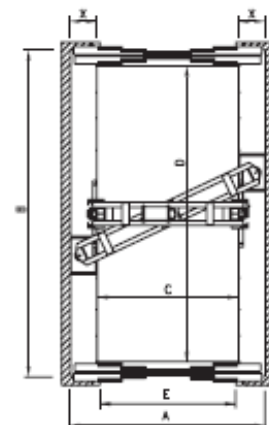

Configurations

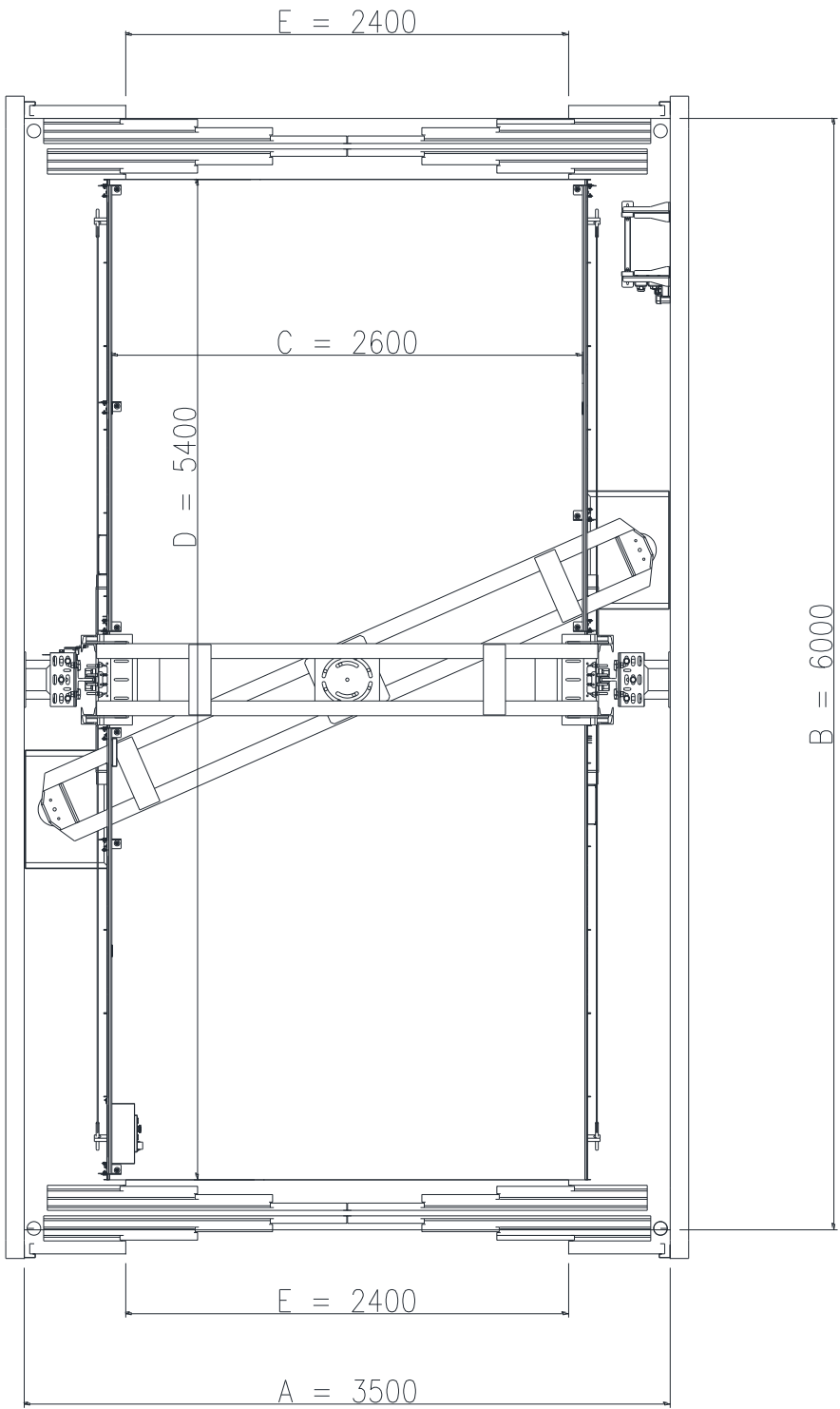

Configurations

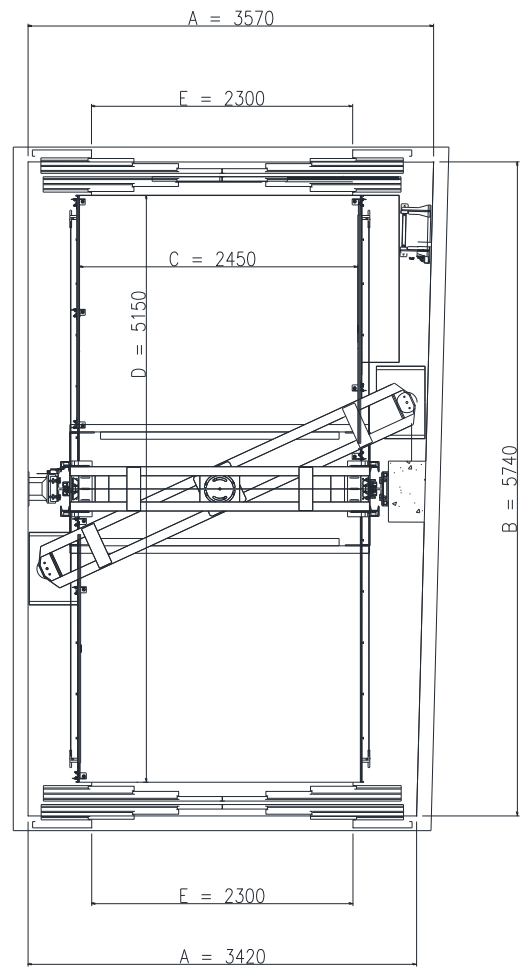
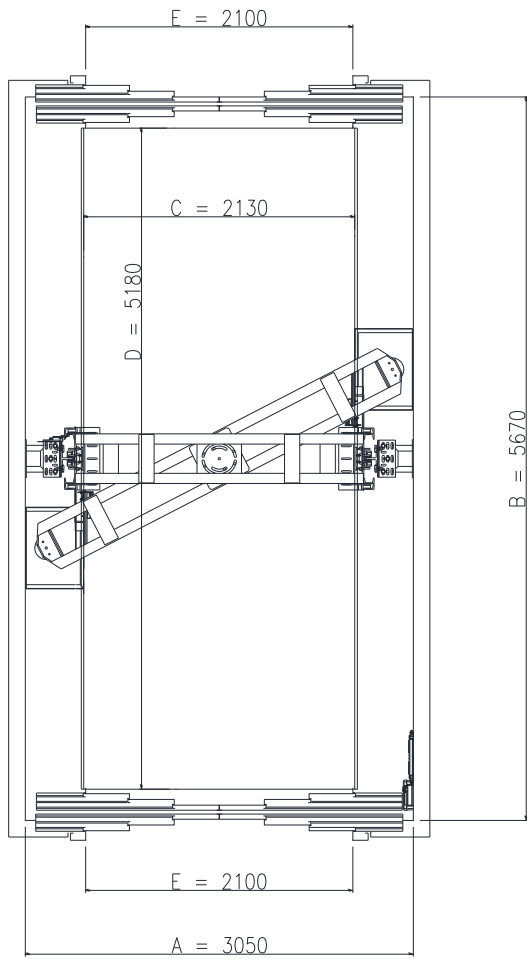

Configurations

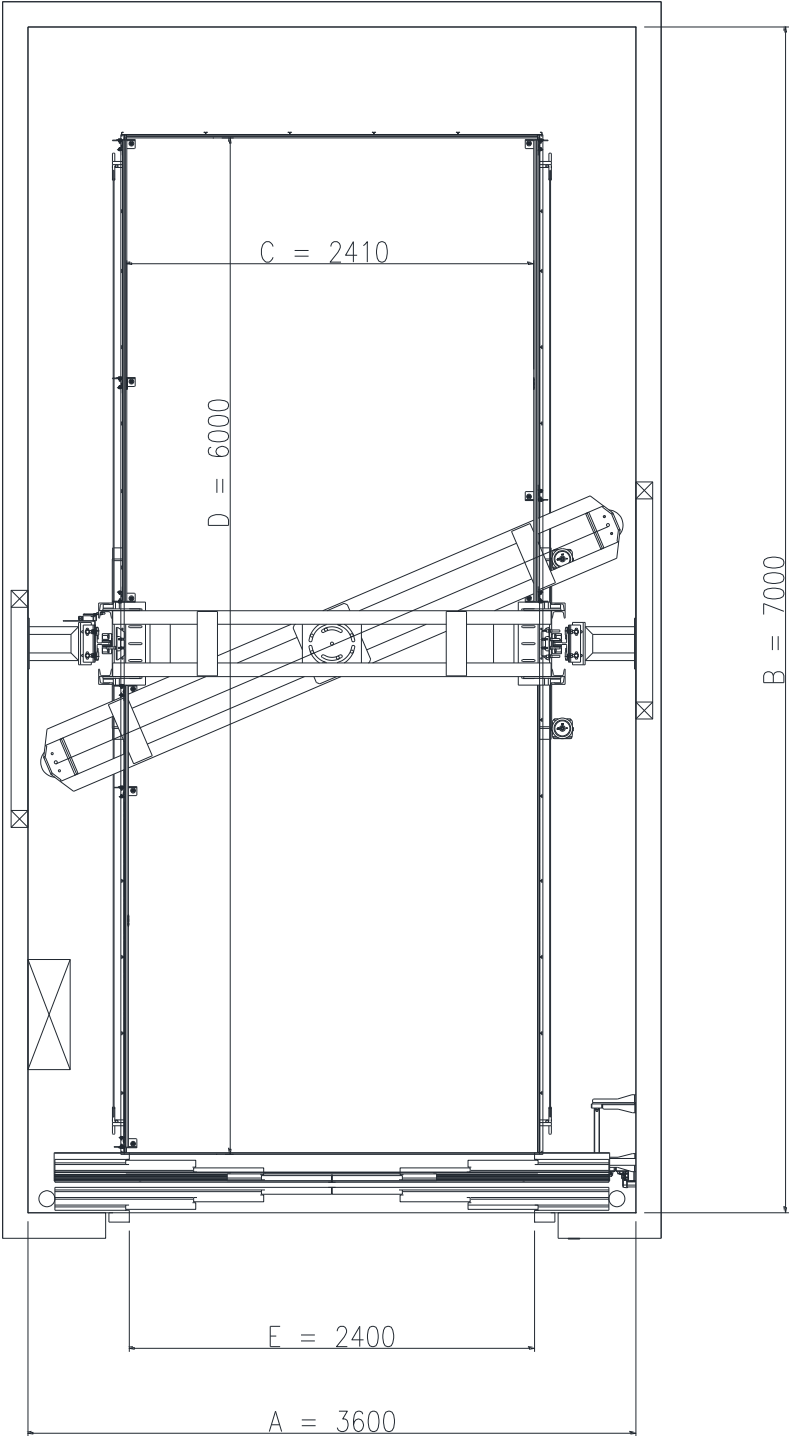

Puissances et Consommations



➤ 2 cylindre / 1:1

Triphase	3000 Kg		3500Kg		4000Kg	
Tension	380III		380III		380III	
P (Kw)	22Kw/30HP	44Kw/60HP	18,4Kw/25HP	29,4Kw/40HP	51Kw/70HP	59Kw/80HP
V (m/s)	0,30	0,63	0,30	0,63	0,30	0,63
I nominale (A)	51	101	68	118	84	134
I démarrage(A)	74	152	98	181	130	208
Démarrage	Étoile/Triangle		Étoile/Triangle		Étoile/Triangle	

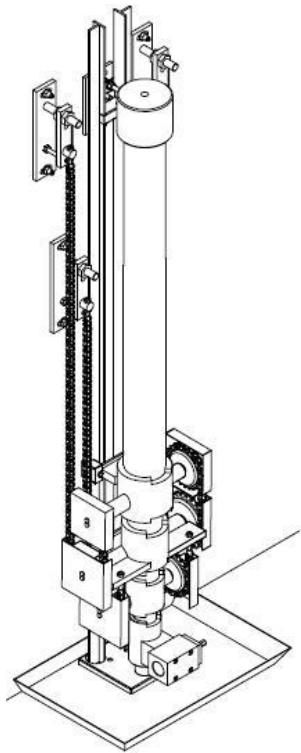

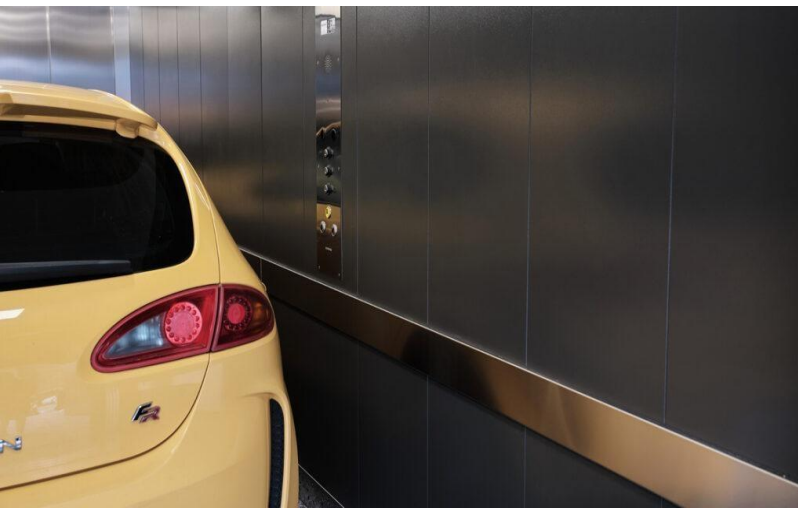

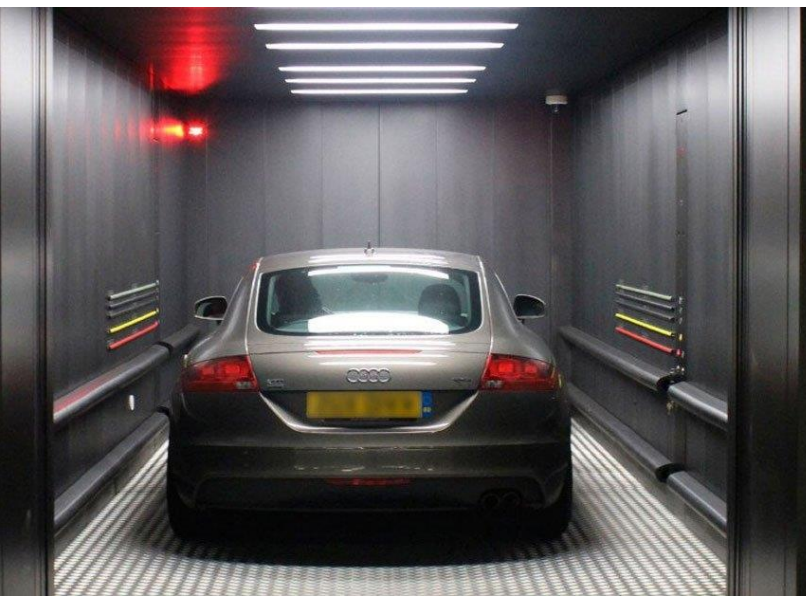
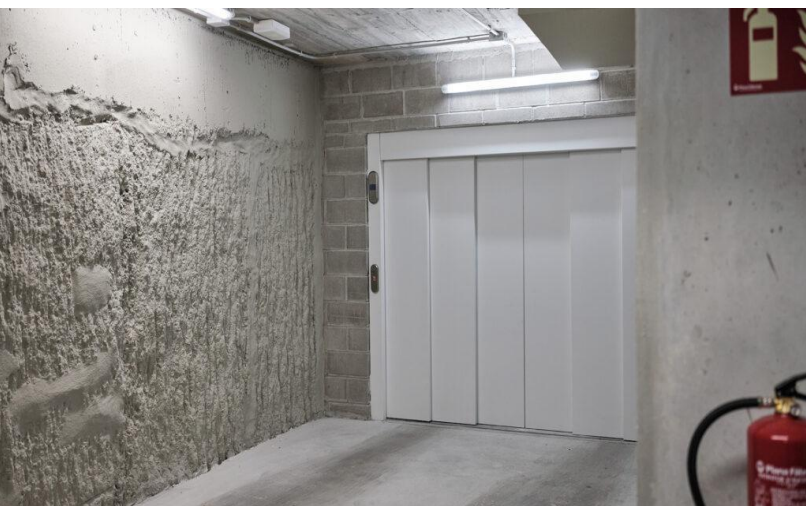

FELES 



www.felesa.com

Moving forward & Moving on