

Moving forward & Moving on

FELES 



MTD  
montaCoches

- Aplicaciones
- Ventajas
- Normativa
- Rango aplicación
- Configuraciones
- Consumos
- Cabinas y acabados
- Galería

## Fiabilidad + Experiencia



Diseñados para el transporte vertical de vehículos en recorridos cortos. Están indicados para edificios dónde es inviable o muy complicado colocar una rampa de acceso.



## Aplicaciones

- Obra nueva / Existente
- Ascensor para vehículos
- Residencial / Industrial

## Ventajas

- Alternativa a rampa parking
- Confort
- Fiabilidad
- Seguridad
- Simples, dobles,
- Tiro directo 1:1 – Fácil montaje

## Normativas

- 2014/33/UE
- EN81-20
- EN81-70
- EN81-73



## Rango aplicación

Carga (Kg)	3000-3500-4000
Velocidad (m/s)	0,2 - 0,6
Cuarto Máquinas	Con cuarto de máquinas
Embarques	0° / 180°
Recorrido Max (m)	20
Suspensión	1:1
Tensión (V)	400III
Chasis	Pórtico
Fosos (mm)	1200
Huidas (mm)	3400
Panorámico	No



## Configuraciones estándar

### ➤ Simple embarque

Carga	Hueco	Cabina	Paso Libre	V	Huida	Foso	Barand
Kg	AxB mm	CxD mm	E mm	m/s	mm	mm	mm
4000	3280x6100	2400x5700	2300	0,3-0,6	3400	1200	700
	3280x6100	2400x5600	2300	0,3-0,6	3400	1200	700
	3380x6000	2500x5600	2300	0,3-0,6	3400	1200	700
	3380x5800	2500x5400	2300	0,3-0,6	3400	1200	700
	3380x5600	2500x5200	2300	0,3-0,6	3400	1200	700
	3480x5800	2600x5400	2300	0,3-0,6	3500	1300	700
	3480x5600	2600x5200	2300	0,3-0,6	3500	1300	700
	3480x5400	2600x5000	2300	0,3-0,6	3500	1300	700

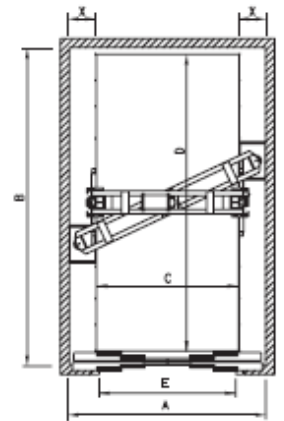

### ➤ Doble embarque 180°

Carga	Hueco	Cabina	Paso Libre	V	Huida	Foso	Barand
Kg	AxB mm	CxD mm	E mm	m/s	mm	mm	mm
4000	3280x6200	2400x5700	2300	0,3-0,6	3400	1200	700
	3280x6100	2400x5600	2300	0,3-0,6	3400	1200	700
	3380x6100	2400x5600	2300	0,3-0,6	3400	1200	700
	3380x5900	2500x5400	2300	0,3-0,6	3400	1200	700
	3380x5700	2500x5200	2300	0,3-0,6	3400	1200	700
	3480x5900	2600x5400	2300	0,3-0,6	3500	1300	700
	3480x5700	2600x5200	2300	0,3-0,6	3500	1300	700
	3480x5500	2600x5000	2300	0,3-0,6	3500	1300	700

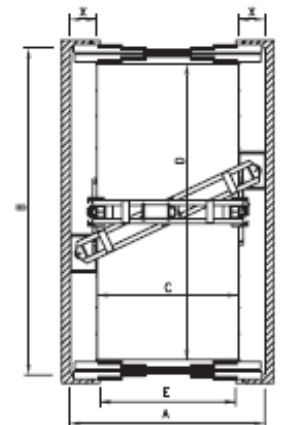

## Configuraciones

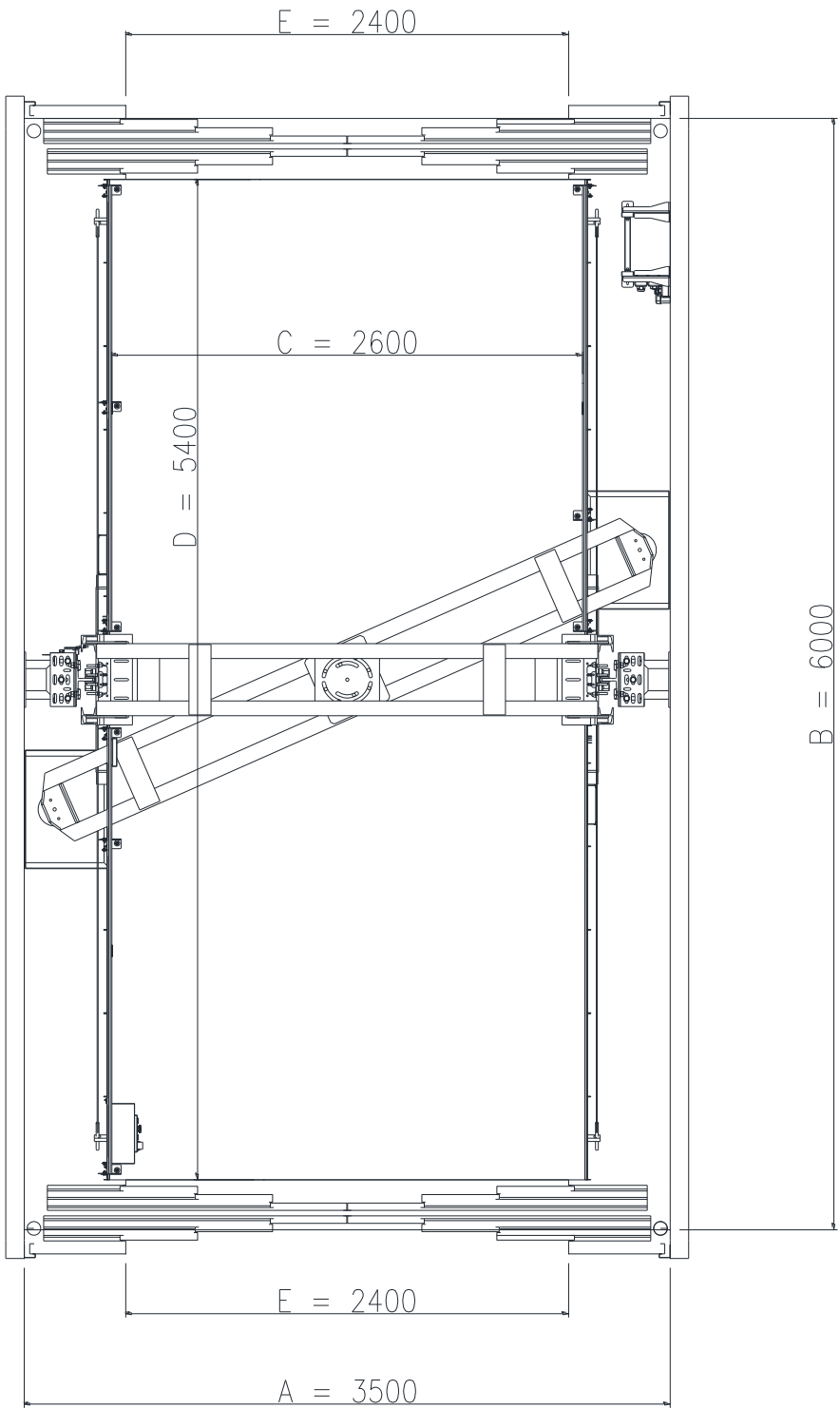

## Configuraciones

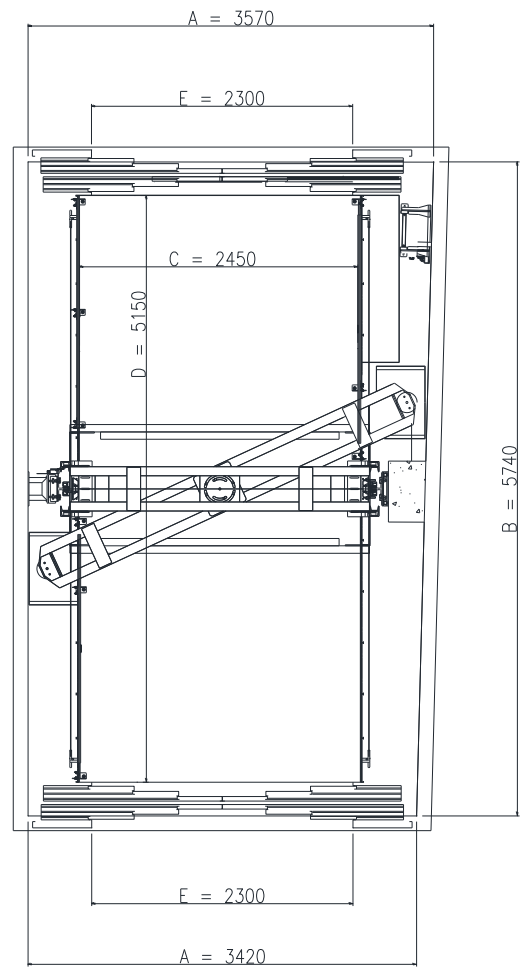
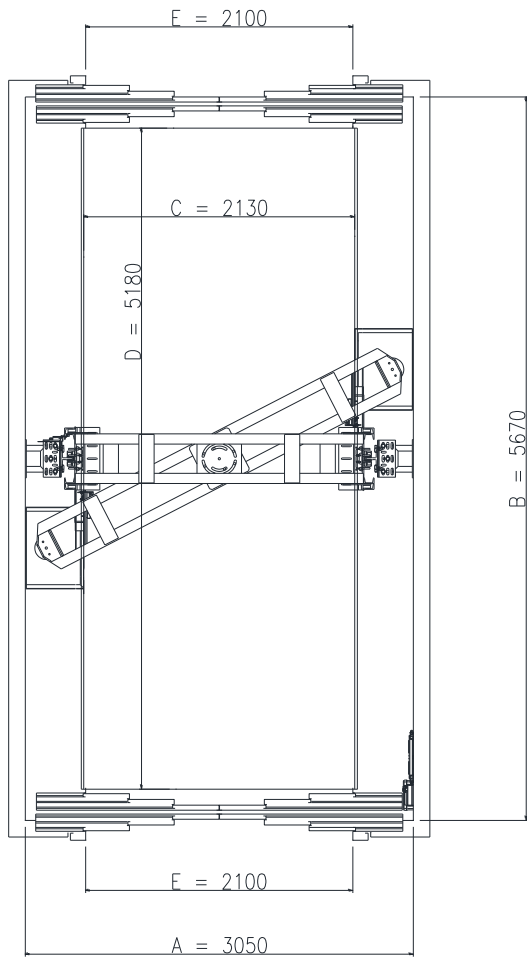

## Configuraciones

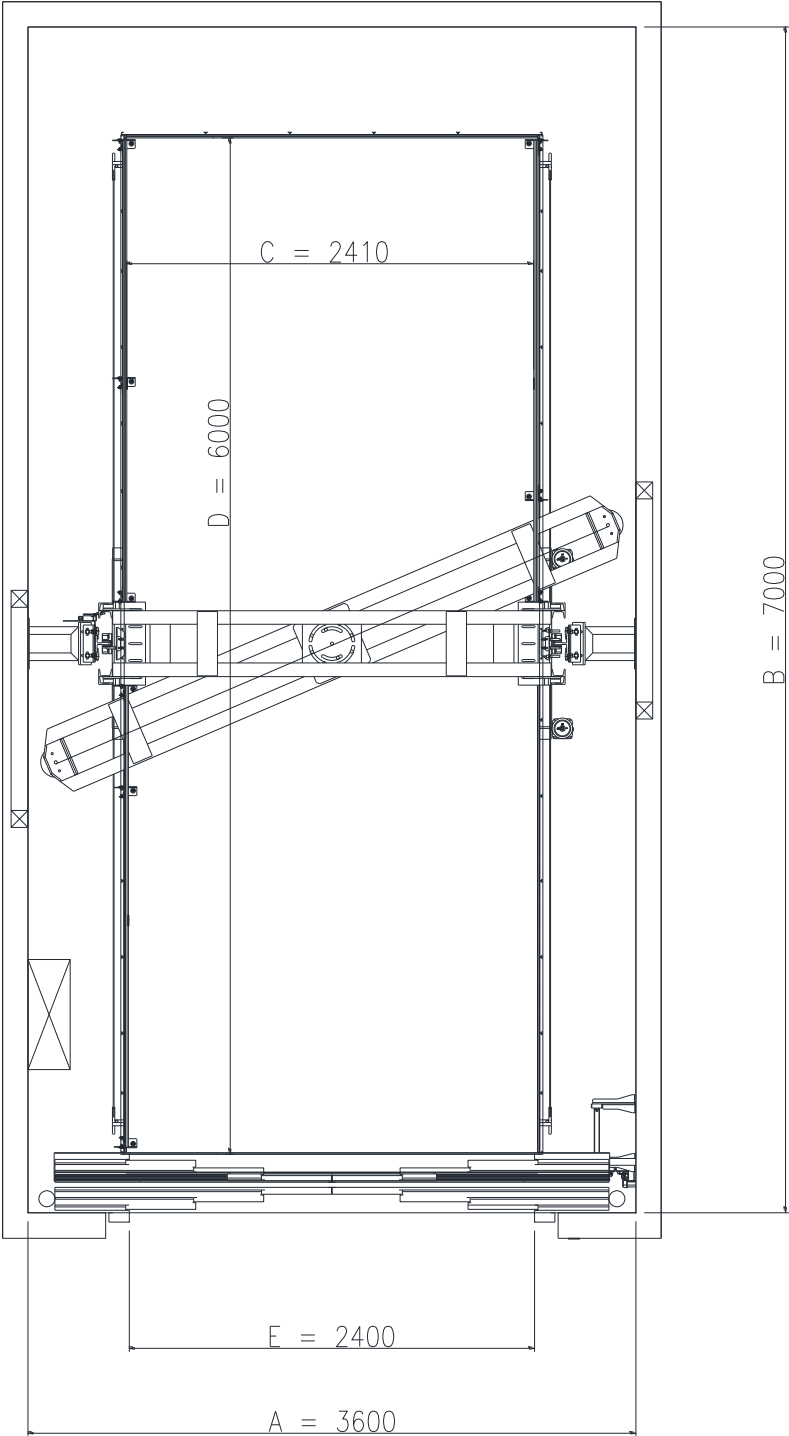



➤ 2 cilindro / 1:1

Trifásicos	3000 Kg		3500Kg		4000Kg	
Tensión	380III		380III		380III	
P (Kw)	22Kw/30HP	44Kw/60HP	18,4Kw/25HP	29,4Kw/40HP	51Kw/70HP	59Kw/80HP
V (m/s)	0,30	0,63	0,30	0,63	0,30	0,63
I nominal (A)	51	101	68	118	84	134
I arranque(A)	74	152	98	181	130	208
Arranque	Estrella/Triángulo		Estrella/Triángulo		Estrella/Triángulo	

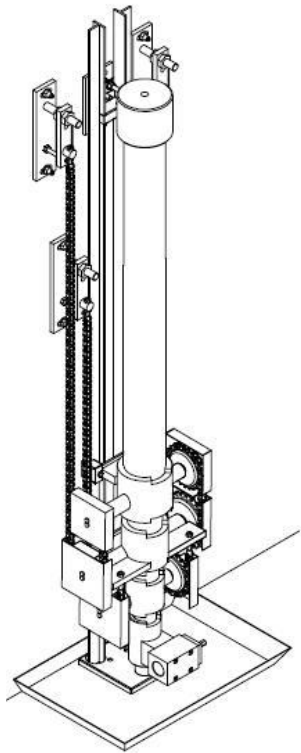



## Cabinas y acabados

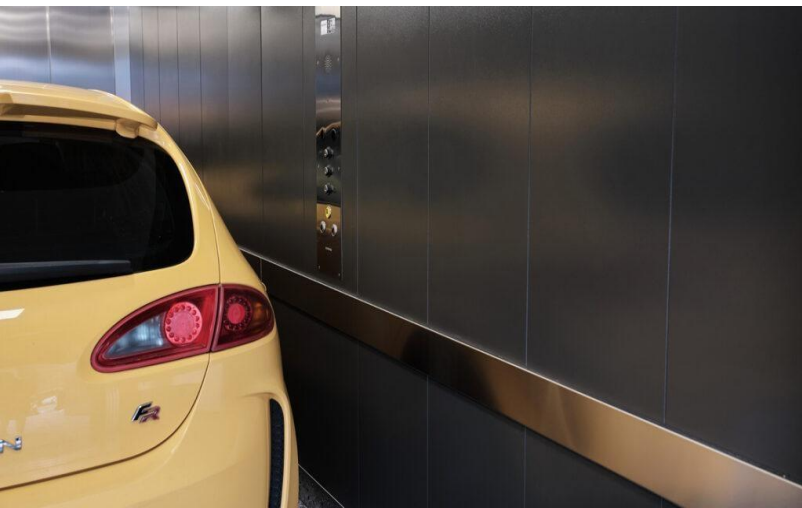



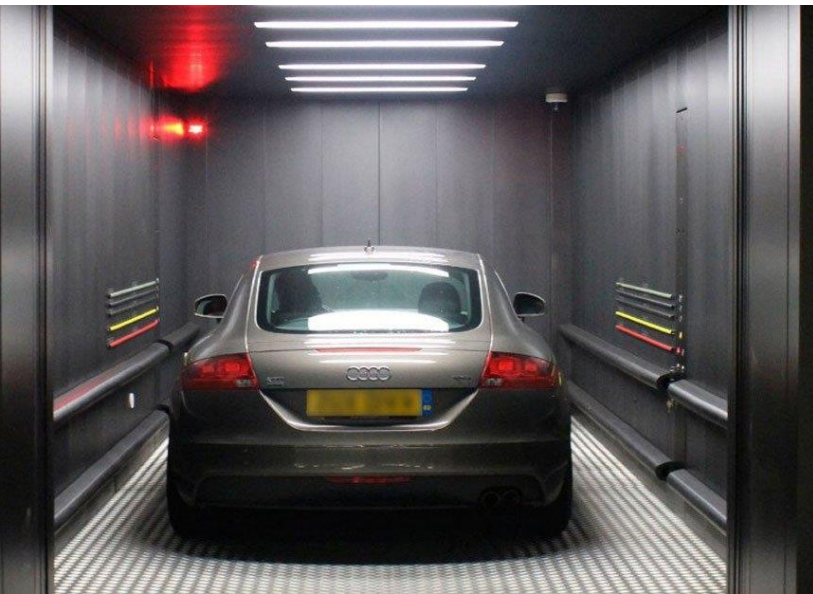

FELES 



[www.felesa.com](http://www.felesa.com)

Moving forward & Moving on