

Moving forward & Moving on

FELES 



Existing Buildings  
Rehabilitations  
Minimum shafts  
Maximum cabins



microGRL

# microGRL

- Applications
- Advantages
- Normative
- Application range
- Variants table
- Pits
- Headrooms
- Standard configuration
- Minimal configurations
- Power and consumption
- Energy efficiency
- Cabines and finishes
- Gallery

## Adaptation + Space



Flexible solutions that adapt to any building and space. We optimize spaces however small they may be. Equipped with the most modern systems of energy efficiency, they improve and optimize life in buildings that do not have an elevator. Also designed to replace old installations to improve safety and adapt them to new regulations.

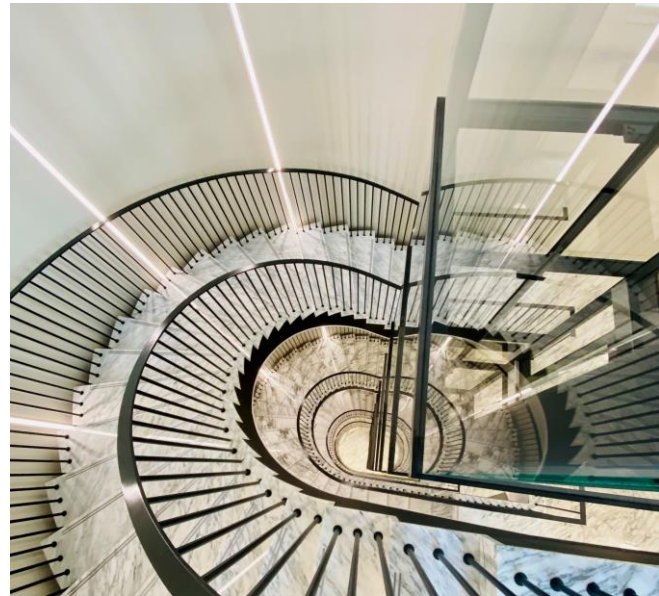



## Applications

- Existing Buildings
- Rehabilitations
- Modernizations
- Refurbishments

## Advantages

- Low pit and headroom EN81-21
- Reduced shafts
- Cabine dimensions maximization
- Configuration flexibility
- Simple, double and triple entrances
- 3-phase/ Single phase

## Standards

- 2014/33/UE
- EN81-20
- EN81-70
- EN81-21

## Application range

Load (Kg)	180 / 225 / 320 / 375 / 480 / 525 / 630
Speed (m/s)	0,6 / 1
Machine room	With motor room / Machine room less
Entrances	0° / 90° / 180° / 270° / Triple
Travel Max (m)	40
Suspension	1:1 / 2:1
Voltage (V)	230II / 230III / 400III
Car Frame	Rucksack
Technical distance (mm)	mGRL1: 250 / mGRL2: 340
Minimum pit (mm)	300mm (see variants table)
Minimum headroom (mm)	2700mm (see variants table)
Panoramics	Yes





## Variants table

Type	CT(mm)	Pit Normal	Low Pit	Headroom Normal	Low Headroom
mGRL1	250	✓		✓	
			✓	✓	
mGRL2	340	✓			✓
			✓		✓

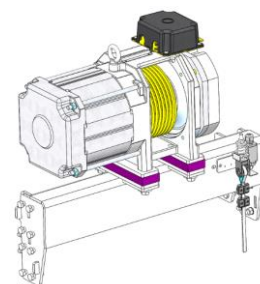

## Pit FR

Type		FR normal	FR EN81-21			
mGRL1	CT250	1010	Rubber floorings		Stone 20mm thickness	
			480 Kg	300mm	480 Kg	320mm
mGRL2	CT340	Selon configuration	630 Kg	350mm	630 Kg	370mm



## Headroom HR

Type		HR normal		AC Cabine Height		HR EN81-21	
mGRL1	CT250	SCM	>3400	<3500	2060		
				>3500	2160		
		CCM	>3270	<3400	2060		
				>3400	2160		
mGRL2	CT340	>3400		2160		2700	<2900 AC 2060
							>2900 AC 2160





## Standard configurations

### ➤ Single entry

Load	Shaft	Cabine	Clear Op.	Speed
Kg	AxB mm	CxD mm	E mm	m/s
320	1350x1150	950x900	700	1
480	1400x1500	1000x1250	800	1
630	1500x1650	1100x1400	900	1

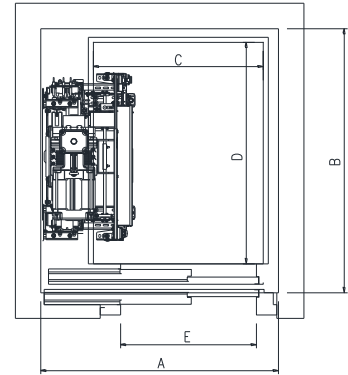

### ➤ Double entry 180°

Load	Shaft	Cabine	Clear Op.	Speed
Kg	AxB mm	CxD mm	E mm	m/s
320	1350x1250	950x900	700	1
480	1400x1600	1000x1250	800	1
630	1500x1750	1100x1400	900	1

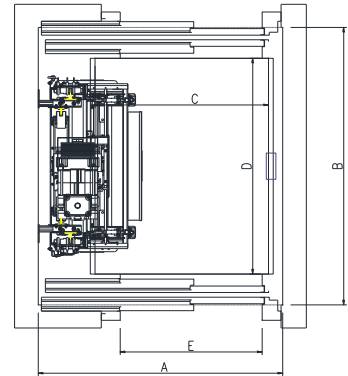

### ➤ Double entry 90°/270°

Load	Shaft	Cabine	Clear Op.	Speed
Kg	AxB mm	CxD mm	E mm	m/s
320	1450x1150	950x900	700	1
480	1500x1500	1000x1250	800	1
630	1600x1650	1100x1400	900	1

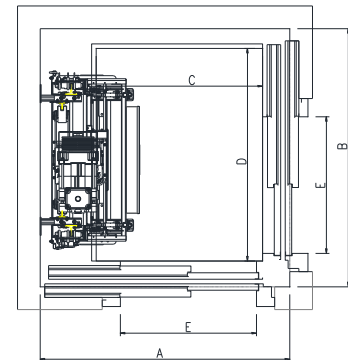

### ➤ Triple entry

Load	Shaft	Cabine	Clear Op.	Speed
Kg	AxB mm	CxD mm	E mm	m/s
320	1450x1250	950x900	700	1
480	1500x1600	1000x1250	800	1
630	1600x1750	1100x1400	900	1

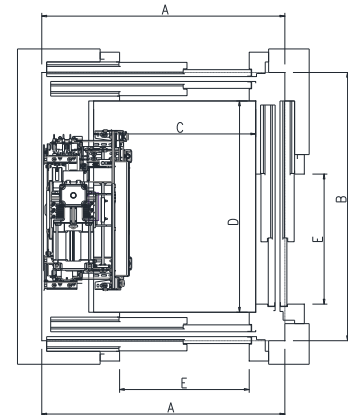

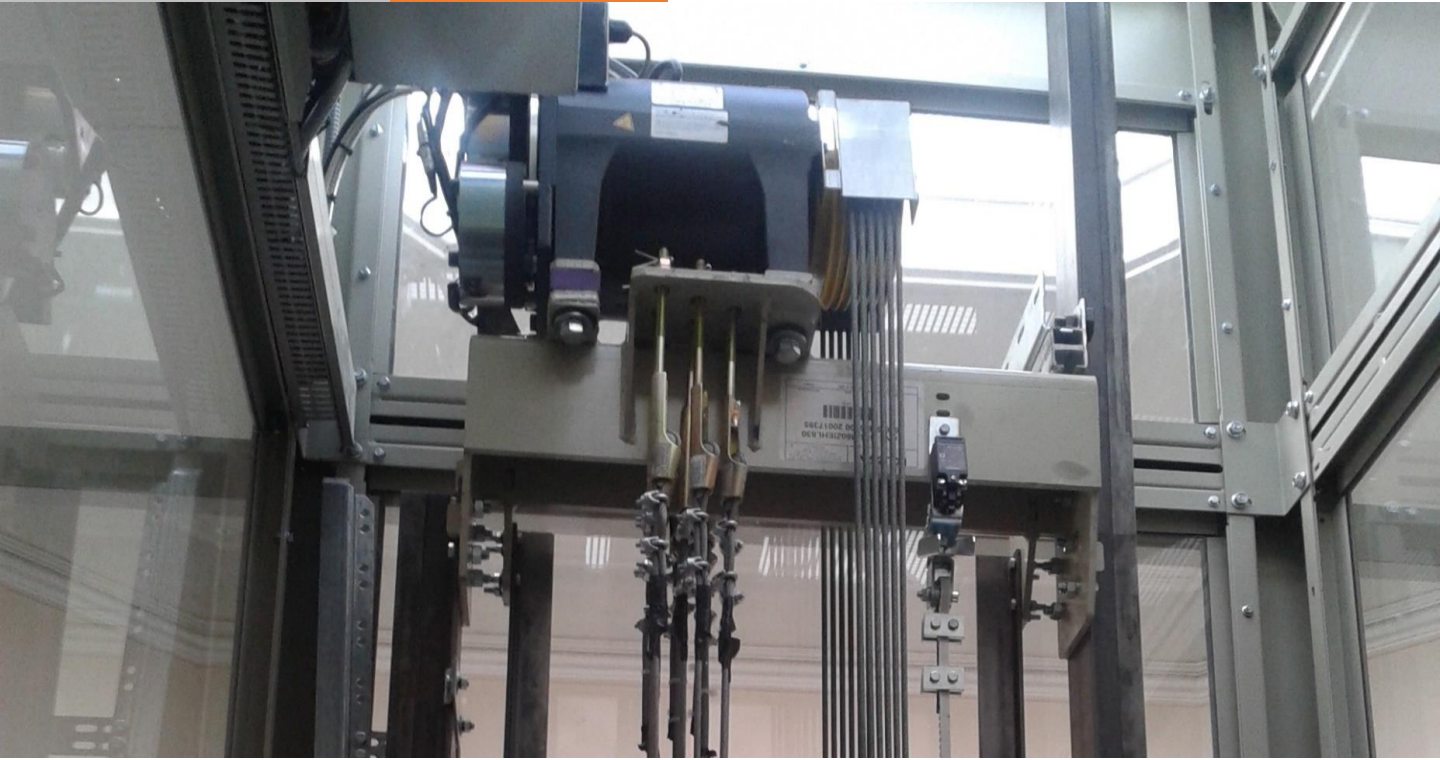

➤ Back wall mechanical

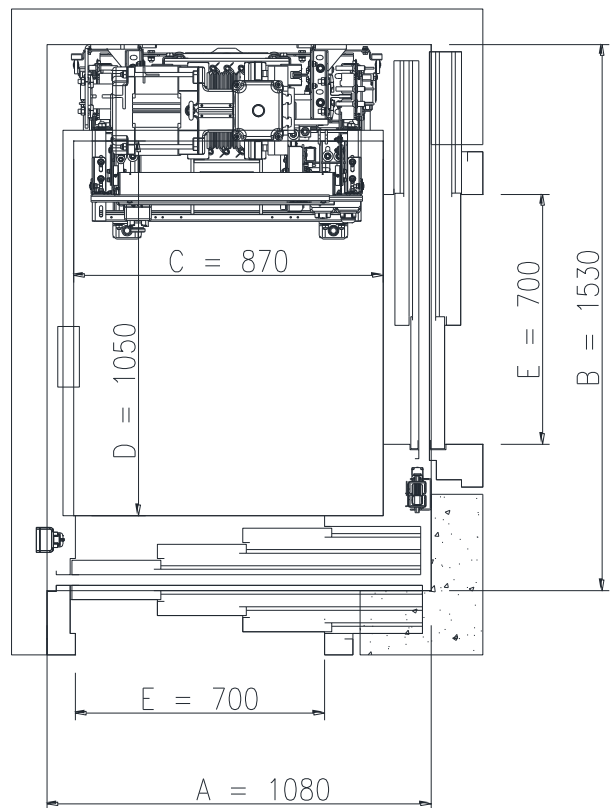
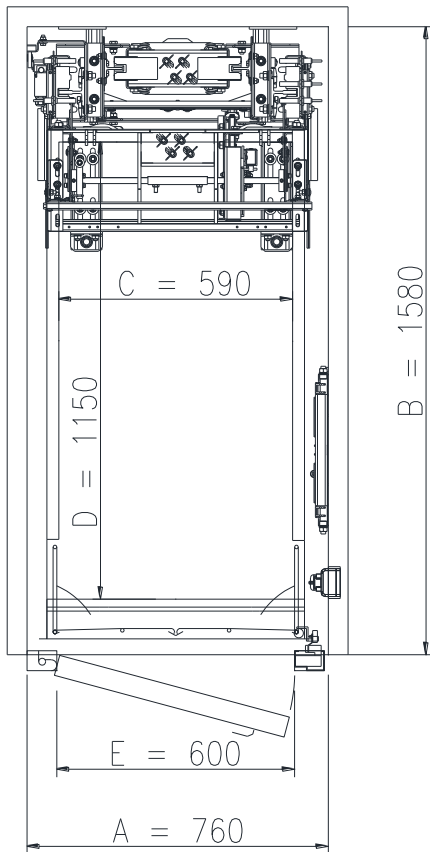

➤ Side wall mechanical

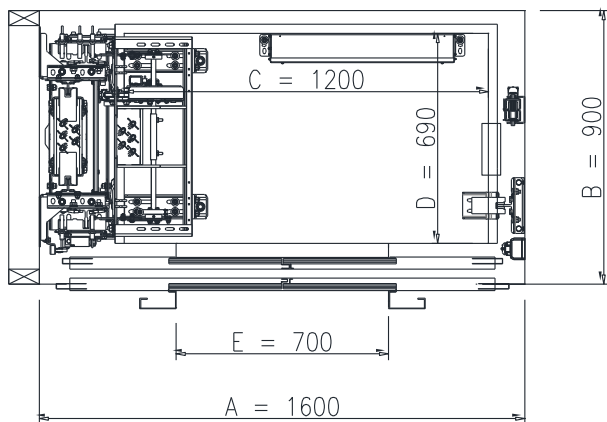
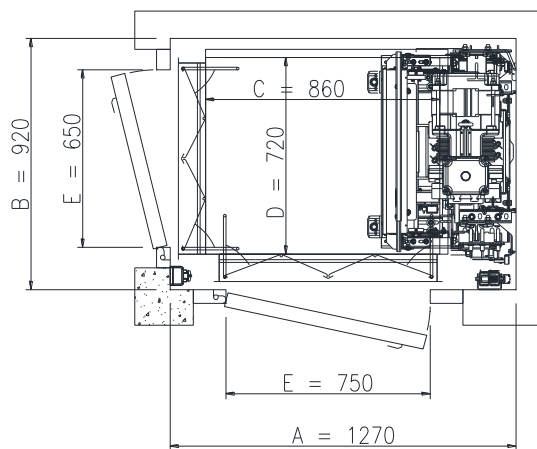
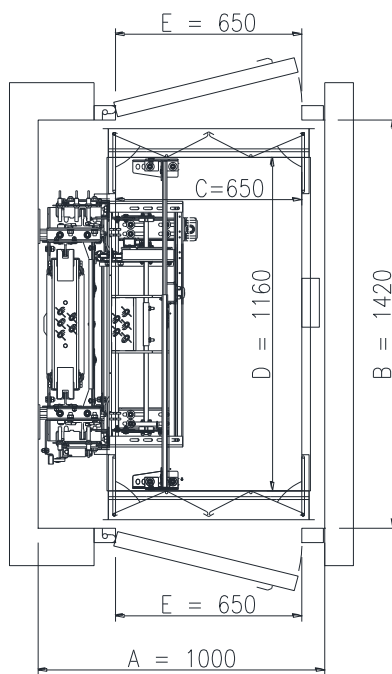
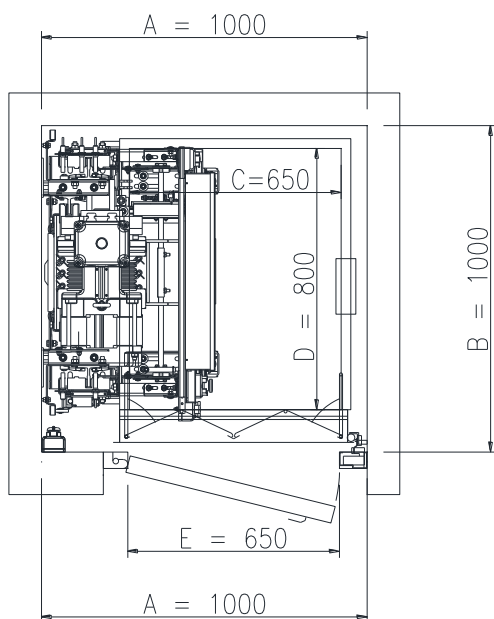

➤ Bespoke

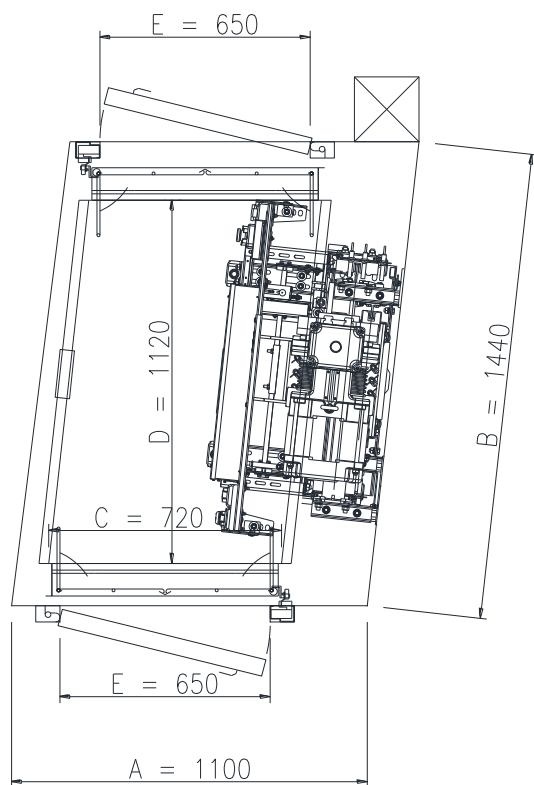
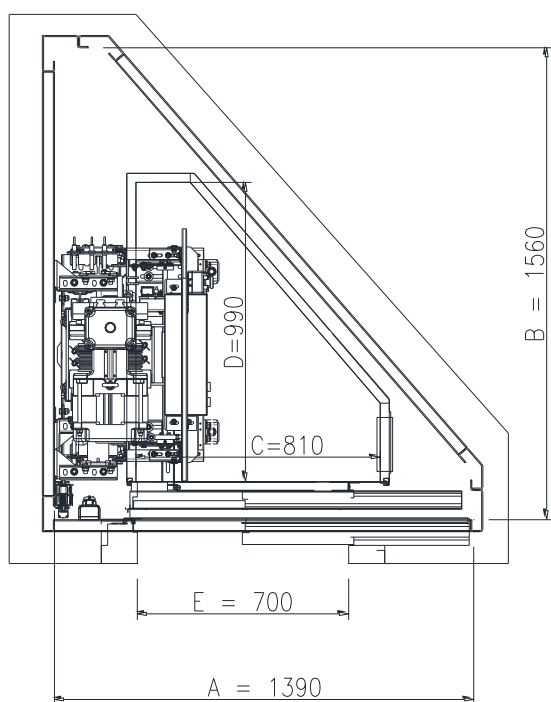
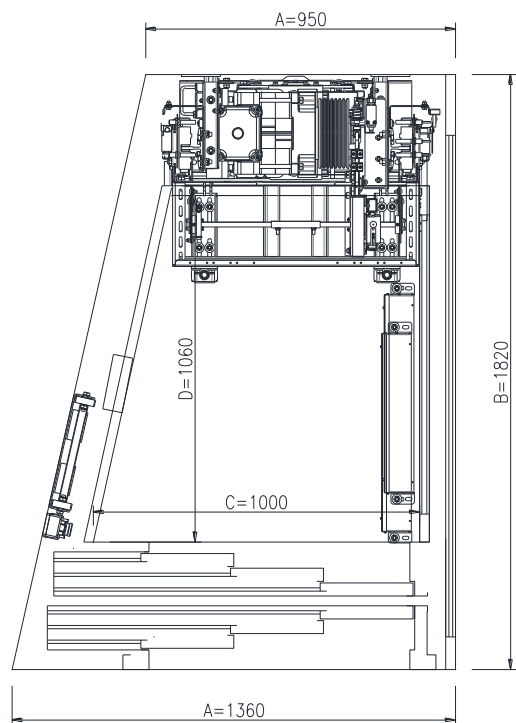





## Power and consumption

3-phase <sup>o</sup>	320 Kg		480Kg		630Kg	
Voltage	380III	230III	380III	230III	380III	230III
P (Kw)	2,1		3,2		4,7	
In (A)	7,5	11,2	10,6	15,9	13,5	20,3
V (m/s)	1		1		1	

Single phase	320 Kg	480Kg	630Kg
Voltage	230II		
P machine (Kw)	1,4	2,1	2,9
P absorbed (Kw)	2,8	4,2	3,8
In motor (A)	7,5	8,7	10,2
In absorbed (A)	13,5	15,7	18,4
V (m/s)	0,6		

## Energy efficiency

### Solar lift with batteries

#### Optional: System P2S Epic Power

- Single phase 220II
- Power 500w
- 100 trips without electricity
- Energy recovery system
- Solar panel connection
- Energy reduction up to 70%

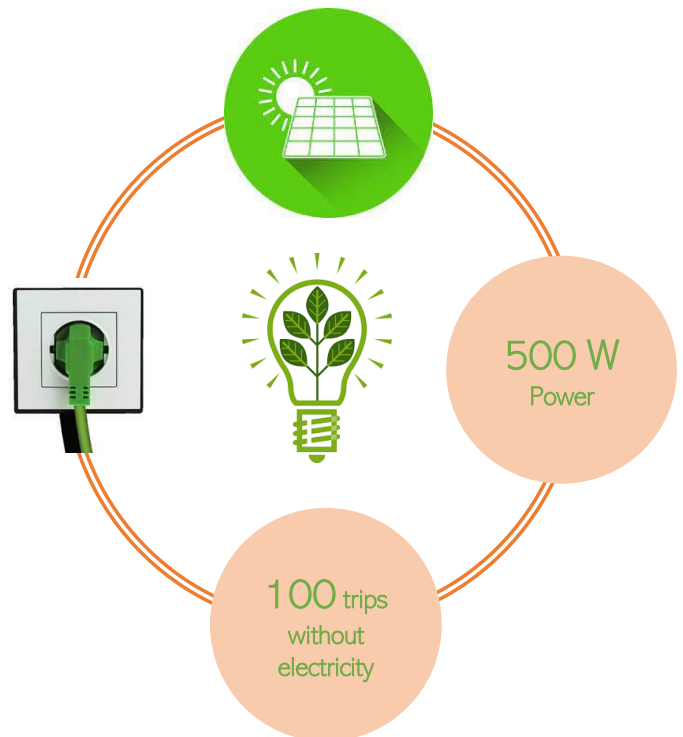
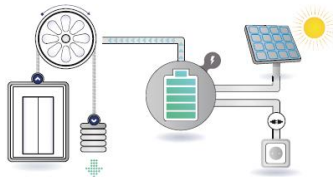

## Cabines and finishes

- Cabines brochure **FELESA SMART** Series
- 8 finishes ranges



CITY



NATURE



TEXTURE



METAL

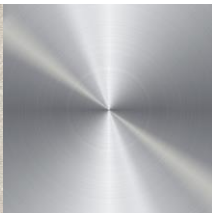

CRYSTAL



ETNIA



STONE



TEXTURE



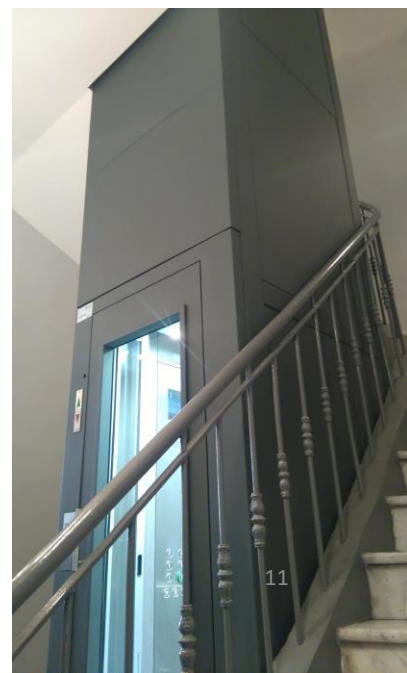
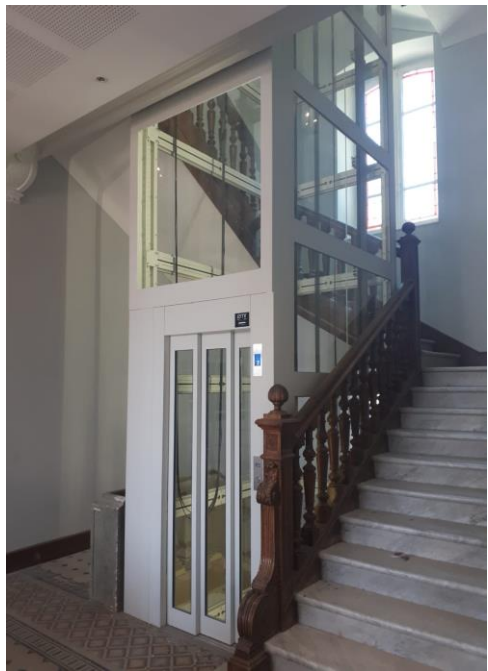
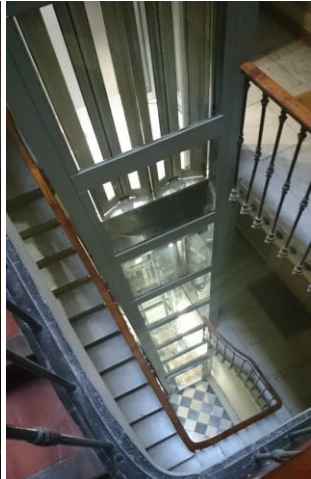
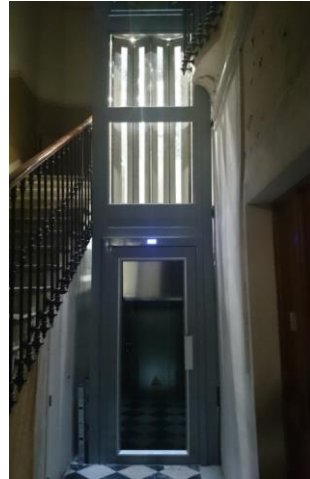

FELES 



Moving forward & Moving on



[www.felesa.com](http://www.felesa.com)